

# LINDSTRAND BALLOONS LTD

## SERVICE BULLETIN No 6

### ISSUE 1 – DATED 24-8-99

- Title: BURNER VALVE REPAIR
- Classification: Recommended
- Applicability: **All** Jetstream Series 2 Double, Triple and Quad Burners identified by the following part numbers:
- BU-008-A-001, BU-008-A-002, BU-010-A-001, BU-010-A-002, BU-010-A-003, BU-012-A-001, BU-012-A-002, BU-012-A-003.
- Serial Numbers Affected: BU425, BU426, BU432, BU433, BU442, BU452, BU461, BU465, BU466, BU467, BU471, BU474, BU475, BU476, BU477, BU483, BU484, BU487, BU488, BU492, BU497, BU498, BU500, BU501, BU502, BU506, BU507, BU508, BU509, BU513, BU514, BU515, BU517, BU518, BU519, BU520, BU521, BU523, BU524, BU525, BU528, BU530, BU531, BU532, BU533, BU534, BU536, BU538, BU539, BU540, BU541, BU542, BU543, BU544, BU545, BU546, BU547, BU548, BU549, BU551, BU556, BU557, BU558, BU559, BU560, BU561, BU562, BU563, BU564, BU571,
- Compliance Standard: Inspection to be achieved before next flight.
- Background: The main and liquid fire blast valves used on the Jetstream Series 2 burner have, in certain installations, been unable to switch off the fuel flow, causing the flame from the liquid fire jet or the coil jet ring to continue burning after the valve has been closed. Investigation has shown this problem to be caused by oversized thrust washers being fitted.

## Accomplishment Instructions:

### Safety

This Service Bulletin requires that the burner be test fired. Implement the usual codes of practice for handling Propane fuel and follow the safety instructions detailed below:

Ensure that the burner test fire is carried out by somebody with experience in the rigging and operation of balloon burners.

When the burner is connected to the fuel supply, do not look directly down onto the burner from above the vapourisation coils.

Wear protective glasses and gloves.

Check for correct valve function by looking at the appropriate jet from the side of the burner and from a safe distance.

Do not stand down wind of the burner when test firing.

Observe all the usual pre-flight safety precautions when test firing the burner.

Ensure the burner is fully vented before implementing any repair action.

### Inspection

- 1 Check that the burner is a Jetstream Series 2 as defined by the burner part numbers identified above. Assemble the burner to the basket and connect to a fuel cylinder in the usual fashion. Test fire the burner by operating all main and liquid valves. Check that the burner flame is extinguished when the valve is closed. If the flame fails to extinguish when any of the valves are closed, then the plastic thrust washer between the valve handle and the valve bonnet must be replaced as described in the Recovery Action section below.
- 2 Using a 150 mm (6") steel rule, measure the valve handle travel i.e. the amount of handle travel available before the valve cam touches the plastic thrust washer. The correct amount of travel may be gauged by reference to figures 1 and 2. This check must be carried out on all main and liquid fire valves and for both toggle action and squeeze action style valves.
- 3 If the valve handle travel is less than the minimum specified on figures 1 and 2, then the plastic thrust washer (items 4 and 13, figs 1 and 2 respectively) must be replaced as described in the Recovery Action section below.

## Recovery Action

In the event that any valve fails to extinguish the burner flame or that the valve handle travel is less than that specified on figures 1 and 2, then all main and liquid valves must be subject to the recovery action as specified below. Upon completion of the inspection and recovery action, the confirmation slip at the end of this Service Bulletin must be completed and returned to Lindstrand Balloons Ltd.

### Toggle Valve

- 1 Disconnect the burner from any fuel supply and fully vent off any remaining fuel from within the burner.
- 2 Do not remove the valve from the valve block. Raise the valve handle and using a 2mm across flats allen key, undo the two grub screws located in the underside of the handle cam by a quarter turn.
- 3 Remove the pivot pin from the handle and withdraw the handle from the valve.
- 4 Using a knife blade if necessary, remove and discard the old plastic thrust washer from the recess in the valve bonnet.
- 5 Select the new thrust washer from the two supplied to give a clearance between the valve handle cam and the plastic thrust washer of between 0.5mm and 1mm (see figure 1). Note the thrust washer thicknesses as follows:

Thrust washer type BU-008-A-050-A	2.5mm thick
Thrust washer type BU-008-A-050-F	2.0mm thick
- 6 Align the pivot holes in the valve handle cam with the hole in the valve stem. Replace the pivot pin ensuring that the machined flat on the pin faces the two grub screws located in the handle cam.
- 7 Fully tighten the grub screws using a 2mm across flats allen key.
- 8 Using a set of feeler gauges, check that the clearance between the valve handle cam and the thrust washer is between 0.5mm and 1mm as shown on figure 1.
- 9 When the repair work has been implemented, assemble the burner to a basket and fuel cylinder in the usual fashion and test fire checking each valve for correct function.
- 10 If during the test it is noted that the burner flame is not fully extinguished when the valve is closed, contact Lindstrand Balloons Ltd.
- 11 Upon successful implementation of the recovery action, make an entry in the log book stating that LBL Service Bulletin No 6 has been implemented. The

logbook must be signed by an inspector approved by the National Airworthiness Authority.

### **Squeeze Action Valve**

- 1 **Disconnect the burner from any fuel supply and fully vent off any remaining fuel from within the burner.**
- 2 Using a 2.5mm across flats allen key, remove the eight countersunk screws from the handle tube.
- 3 Using a 4mm across flats allen key, remove the four socket head cap screws and crinkle washers securing the upper and lower valve posts to the valve block.
- 4 Remove the handle tube from the upper valve posts.
- 5 Remove the upper and lower valve posts.
- 6 Using a pair of external circlip pliers, remove the circlip from the pivot pin securing the handle cam to the valve spindle.
- 7 Remove the pivot pin.
- 8 Remove the handle assembly taking care to retain the spring and spring cap within the cam.
- 9 Using a knife blade if necessary, remove and discard the old plastic thrust washer from the recess in the valve bonnet.
- 10 Select the new thrust washer from the two supplied to give a clearance between the valve handle cam and the plastic thrust washer of between 0.5mm and 1mm (see figure 2). Note the thrust washer thicknesses as follows:  

Thrust washer type BU-008-A-050-A	2.5mm thick
Thrust washer type BU-008-A-050-F	2.0mm thick
- 11 Align the holes in the handle cam with the hole in the valve spindle and replace the pivot pin.
- 12 Fit a new circlip to the pivot pin using a pair of external circlip pliers.
- 13 Using a set of feeler gauges, check that the clearance between the valve handle cam and the thrust washer is between 0.5mm and 1mm as shown on figure 2.
- 14 Place the lower and upper valve posts in position and fit the handle tube.

- 15 Replace the four hexagon drive cap head screws and crinkle washers and finger tighten.
- 16 Apply Loctite 222 to the eight countersunk screws and replace such that they secure the handle tube to the upper valve post. Fully tighten using a 2.5mm allen key.
- 17 Fully tighten the four hexagon drive cap head screws using a 4mm allen key.
- 18 Check the clearance between the cam and plastic thrust washer as described above.
- 19 When the repair work has been implemented, assemble the burner to a basket and fuel cylinder in the usual fashion and test fire checking each valve for correct function.
- 20 If during the test it is noted that the burner flame is not fully extinguished when the valve is closed, contact Lindstrand Balloons Ltd.
- 21 Upon successful implementation of the recovery action, make an entry in the log book stating that LBL Service Bulletin No 6 has been implemented. The log book entry must be signed by an inspector approved by the appropriate National Airworthiness Authority.

Lindstrand Balloons Ltd  
Service Bulletin No 6 Confirmation Slip

I have carried out the inspection requirements of LBL Service Bulletin No 6.

No further action was required\*

I have replaced the valve thrust washers as specified in LBL Service Bulletin No 6\*

\* Delete as required.

Burner Serial Number.....

Signed..... Date.....

Please return this slip to:  
Lindstrand Balloons Ltd, Maesburey Road, Oswestry, Shropshire, SY10 8ZZ,  
England.

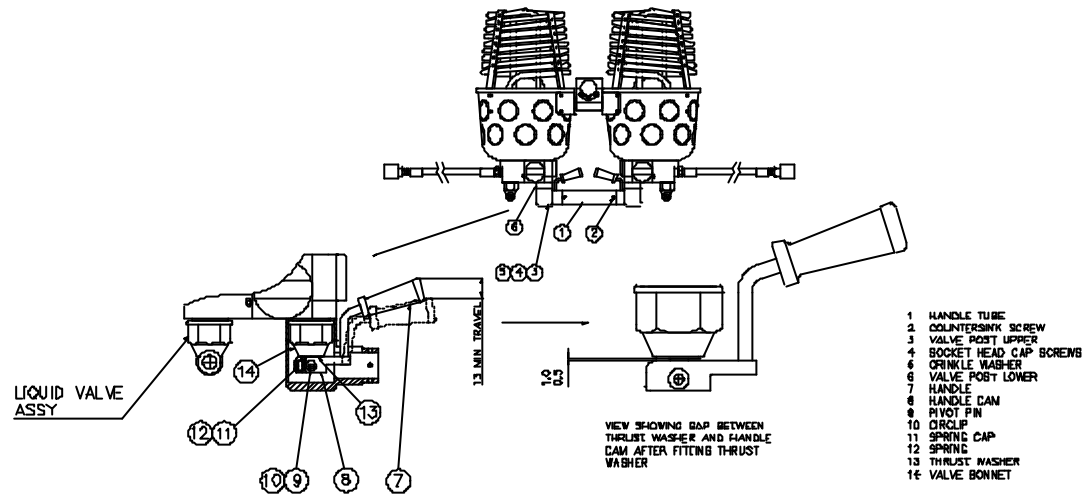

LBL586

FIG 2. JETSTREAM SERIES 2 BURNER SQUEEZE ACTION MODE

PAGE 6 OF 8 FI-BU071

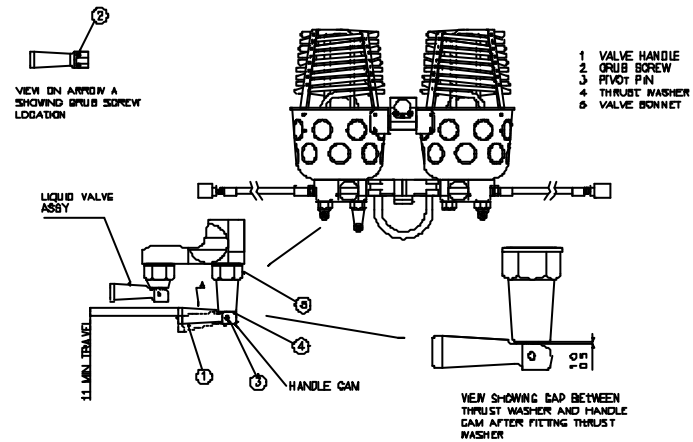

LBL586

FIG 1. JETSTREAM SERIES 2 BURNER TOGGLE ACTION MODE

PAGE 7 OF 8 FI-BU071