



LINDSTRAND BALLOONS LTD

MAINTENANCE MANUAL SUPPLEMENT NO. 3

SERIES 2 CLOUDHOPPER BOTTOM END

SECTION 1 - INTRODUCTION

This Supplement describes the maintenance requirements for the Series 2 Cloudhopper Bottom End.

SECTION 2 – DEFINITION

The Series 2 Cloudhopper Bottom End is defined by the following drawing numbers:

BA-310-A-001 (Cloudhopper General Assembly)

BA-310-A-002 (Cloudhopper General Assembly – German and American variant)

SECTION 3 – OVERVIEW

3.1 General

The Series 2 Cloudhopper Bottom End is designed for use with all LBL Cloudhopper envelopes. The equipment is provided with a rear frame, a seat assembly, a five-point pilot harness, adapter tubes, and burner, and is designed in such a way as to allow rapid assembly from a “flat pack” transportation bag.

The equipment is designed for use with any standard LBL V20, V30 or V40 fuel cylinder. Other manufacturers cylinders may be used, provided approval is gained from Lindstrand Balloons Ltd.

The burner has been specifically designed for use with the Series 2 Cloudhopper, but uses parts already used in the Jetstream series of burners.

For convenience, the maintenance requirements for the equipment are dealt with on a sub-system basis:

- Burner Assembly
- Adapter Tubes
- Rear Frame Assembly
- Seat Assembly
- Pilot Harness
- Fuel System
- Foot Rest Assembly

3.2 Burner Assembly

The burner assembly is effectively a single system burner with a special valve block designed to act as a load bearing component. The burner assembly is provided with a single vapourising coil, a main burner valve, a liquid fire valve, a fuel pressure gauge, a regulator valve, igniter assembly, and a load ring.



3.2.1 Main Vapourising Coil

The burner is provided with a single vapourising coil. The main fuel feed into the coil is through a single axial tube, terminated at the valve block with a male bulkhead coupling. The coil is secured to the valve block by the four coil support strips and using cap head screws. Note that the geometry of the coil is different to that used on the Series 1 Cloudhopper and as such, Series 1 and Series 2 Cloudhopper coils are not interchangeable.

3.2.2 Liquid Fire Valve

The design and function of the valve is as described in Section 3.4.1.2 of the Maintenance Manual (see Item 4, Figure 5.1).

3.2.3 Main Burner Valve

The design and function of the valve is as described in Section 3.4.1.2 of the Maintenance Manual (see Item 3, Figure 5.1).

3.2.4 Pilot Light Valve and Regulator

The design and function of the pilot light valve and regulator is as described in Section 3.4.1.3 of the Maintenance Manual (see Item 5, Figure 5.1).

3.2.5 High Voltage Ignition System

The design and function of the piezo igniter is as described in Section 3.4.1.4 of the Maintenance Manual (see Item 9, Figure 5.1).

3.2.6 Pressure Gauge

The design and function of the pressure gauge is as described in Section 3.4.1.5 of the Maintenance Manual (see Item 6, Figure 5.1). Note that the allowable working fuel pressure range indicated on the gauge is different to that used in other Jetstream burners and as such, Jetstream burner gauges must not be fitted.

3.2.7 Liquid Fire Nozzle

The design and function of the liquid fire nozzle is similar to that as described in Section 3.4.1.6 of the Maintenance Manual. Note that the liquid fire nozzle assembly fitted in the Series 2 Cloudhopper bottom end burner is different to that fitted in other Jetstream burners in that it has been down-jetted to prevent excessive fuel flows. Care must be taken to ensure that the correct liquid fire jet is fitted, as fitment of the wrong part may result in serious heat damage to the envelope. The liquid fire jet assembly may be seen as Item 8, Figure 5.1.

3.3 Adapter Tubes

The adapter tubes consist of bent stainless steel tube. One end of each tube is inserted into the burner valve block and secured in place using two pip pins per tube. The other end of the tubes are positioned over the machined tubes on the top of the rear frame and are secured in place using two shaft locking pins per tube.

The adapter tubes form a structural link between the burner and the rear frame and it is therefore important that only the correct tubes conforming to Lindstrand Balloons Ltd specifications are used. The adapter tubes are shown as Item 5, Figure 3.1.



3.4 Rear Frame Assembly

The rear frame assembly is constructed from bent and welded stainless steel tube and provides all the attachment points for the seat, harness, fuel cylinder, and fuel hoses. The frame attaches to the two adapter tubes using two shaft locking pins per tube.

The rear frame is structural and provides support for the pilot and fuel cylinder. The rear frame is shown as Item 1, Figure 3.1.

3.5 Seat Assembly

The seat assembly is a combined plywood and fabric construction using load tape as the means of suspension. A cordura fabric pocket encloses a plywood base fitted with foam padding. A load tape passes around the underside of the cordura pocket and is provided with rapid links as the means of attachment to the rear frame. Two short load tapes terminated in rapid links are situated at the rear underside of the cordura pocket and, when attached to the rear frame, form the seat rear support. The seat assembly is shown as Item 4, Figure 3.1.

3.6 Pilot Harness

The pilot harness is a five-point system constructed from 45 mm width webbing and buckles. Each harness strap is attached to the rear frame using a rapid link. The harness consists of one "between the leg" strap (Item 20, Figure 3.1), two waist straps (Item 18, Figure 3.1) and two shoulder straps (Item 17, Figure 3.1). Each strap is provided with adjustment to suit individual pilot requirements.

The lower "between the leg" strap passes through a slot in the seat assembly and is fitted with a five-point rotation buckle, allowing easy locking and unlocking of the harness. A protective flap is also provided, which when placed in position, prevents inadvertent operation of the harness rotation buckle.

3.7 Fuel System

The equipment is designed for use with standard vertical orientation V20, V30 or V40 fuel cylinders. The design and function of the cylinders is as described in Section 3.3 of the Maintenance Manual.

Connection to the fuel cylinder is by a fuel hose (Item 9, Figure 3.1) with either a Rego or Tema female coupling. The other end of the hose is attached to a stainless steel ball valve (Item 1, Figure 5.2) mounted on the upper cross bar of the rear frame. Another hose is mounted on the valve outlet. This hose is terminated with a female Tema coupling which is connected to the mating connector fitted on the burner valve block.

An adjustable mirror is provided for the purposes of viewing the cylinder contents gauge. The mirror is mounted in two nylon claws attached to the adapter tubes. The mounting arrangement is such that the mirror may be removed, allowing for equipment assembly / disassembly. The mirror is shown as Item 8, Figure 3.1.

3.8 Foot Rest Assembly

A foot rest assembly is provided for pilot comfort. The foot rest consists of a stainless steel tube and two adjustable load tapes terminated with snap hooks. The snap hooks connect to two "D" lugs mounted on the seat front suspension load tape. The foot rest assembly is shown as Item 19, Figure 3.1.

SECTION 4 – PREVENTATIVE MAINTENANCE

4.1 Storage and Handling

For the purposes of storage and handling, the equipment shall be considered in three main areas:



4.1.1 Burner

The burner assembly is of great importance and should therefore be handled and stored with care. When not in use, the burner should always be removed from the Cloudhopper assembly and stored in its' protective bag.

The burner may be placed carefully on its' side on soft ground if required whilst handling, but care must be taken not to damage the load ring. Due to the risk of overbalancing, it is recommended that the burner is not rested vertically on its' coil.

Care should be taken when dismantling the burner, to keep the male Tema feed connector fitted on the valve block clean.

4.1.2 Rear Frame, Seat, Harness and Adapter Tubes

For ease, the rear frame should be stored in a suitable bag with the seat assembly and harness assembly left attached. To avoid wear, especially to the harness and seat, avoid placing the equipment on hard or rough ground. Care should be taken to prevent damage to all parts of the equipment, especially the "D" lugs, triangular lugs and cylinder keep plate, which are welded to the rear frame.

When handling the equipment, ensure that the fuel hoses and couplings and the intermediate fuel valve are protected. Do not place the fuel couplings directly on the ground without having first fitted the protective dust covers.

The adapter tubes should always be handled carefully and stowed in a suitable bag. Avoid dropping the tubes onto hard ground, or handling them in any way which could cause denting. A dented adapter tube must be replaced.

4.1.3 Fuel Cylinder

The handling and storage requirements for the fuel cylinder are as described in Sections 4.4.1.1 and 4.4.1.2 of the Maintenance Manual.

4.2 Cleaning

4.2.1 Burner

The cleaning requirements for the burner are as described in Section 4.5.3 of the Maintenance Manual.

In addition, ensure that the load ring and roller bearings are free from dirt. Remove any dirt from the load ring and bearings with a suitable cloth. Do not apply any solvent when cleaning the load ring and bearings, as this could cause deterioration of the bearing lubricants.

Check that the two sockets at the rear of the valve block which accept the adapter tubes are free from dirt or grit and that the male Tema fuel inlet connector is clean. Clean the sockets and connector with a cloth, or with an air line, as appropriate.

4.2.2 Rear Frame, Seat, Harness and Adapter Tubes

The rear frame may be cleaned using a soft damp cloth. Ensure there is no dirt or grit on the two machined tubes which slot into the adapter tubes.

Dirt may be removed from the seat and harness using a cloth, or clothes brush, as appropriate.

Ensure the adapter tubes are always kept clean, both internally and externally. External dirt may be removed using a damp cloth, or cloth soaked in solvent if necessary. Any dirt close to the securing pin holes should be removed using an air line if necessary.

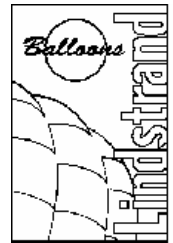

5.1 Burner

The serviceable items within the burner are identical to those described in Section 5.4 of the Maintenance Manual, with the following additions or changes:

5.1.1 Load Ring

The load ring must be replaced if it shows any signs of cracking, fatigue, bending or warping, or undue wear, particularly on the holes where the rapid links are attached.

To remove the load ring, proceed as follows:

Ensure the burner is fully vented.

Using a 5 mm AF Allen key, remove the hexagon drive cap head screw (Item 25, Figure 5.1), securing the front location bush (Item 11, Figure 5.1). Remove the location bush.

Using a 5 mm AF Allen key, remove the two hexagon drive cap head screws (Item 26, Figure 5.1), securing the two small roller bearings (Item 12, Figure 5.1) to the underside of the valve block. Remove the retaining washers, bearings and lower spacers.

Withdraw the load ring.

Replacement of the load ring is the reverse procedure of the above. Ensure that the load ring is fitted with the square section groove uppermost, so that the six roll pins fitted in the valve block run inside the groove.

Ensure that the position of the spacer and retaining washers are correct when replacing the bearings (see Figure 5.1).

Ensure the screws are fully tightened and that the bearings are free to rotate.

5.1.2 Lower Bearings

The two lower bearings should be replaced if they show signs of wear, if their operation is no longer smooth, or if they have been subject to impact.

The two lower roller bearings (Item 12, Figure 5.1) may be removed as described in Section 5.1.1 above.

5.1.3 Upper Bearings

The upper bearings should be replaced if they show signs of wear, if their operation is no longer smooth, or if they have been subject to impact.

To remove the upper bearings, proceed as follows:

Using a flat bladed screwdriver, remove the M8 slotted head screw (Item 27, Figure 5.1) from the valve block. Remove the two plain washers and the bearing.

Replacement of the bearing is generally the reverse procedure of removal. Ensure that a washer is placed each side of the bearing. Ensure that the M8 securing screws are fully tightened and that the bearing is free to rotate.



5.1.4 Coil Assembly

To remove the coil assembly, proceed as follows:

Using two 19 mm AF open-ended spanners, undo the upper nut of the male bulkhead coupling (Item 16, Figure 5.1), securing the coil down tube to the valve block. During this process, prevent the body of the bulkhead coupling from rotating by using one of the spanners.

Using a 5 mm AF Allen key, undo and remove the four hexagon drive cap head screws and washers (Items 28 and 29, Figure 5.1), securing the four coil support strips to the valve block.

Carefully remove the coil.

Replacement of the coil is generally the reverse procedure of removal. Upon completion of the coil replacement, attach a 100 psi air line to the fuel inlet coupling. Open the main valve. Apply soapy water to the area of the male bulkhead coupling and check for the presence of any bubbles. If any bubbles are noted, there is a leak which must be rectified.

5.1.5 Male Bulkhead Coupling (Coil to Valve Block)

To remove the male bulkhead coupling (Item 16, Figure 5.1), securing the coil down tube to the valve block, proceed as follows:

Remove the coil, as described in Section 5.1.4 above.

Using a 19 mm AF open-ended spanner, undo the bulkhead coupling.

Remove the bulkhead coupling and bonded washer.

Replacement of the bulkhead coupling is generally the reverse procedure of removal. Always replace the bonded washer with a new one. Upon replacement and re-assembly of the coil, air pressure test the joint as described in Section 5.1.4 above.

5.1.6 Male Tema Connector

To remove the male Tema fuel inlet connector (Item 17, Figure 5.1) from the rear of the valve block, proceed as follows:

Using a 22 mm ring or open-ended spanner, undo the Tema coupling. Note that the Tema coupling is attached to the valve block with a male to male bulkhead adapter (Item 18, Figure 5.1). The across flats dimension of this adapter may change between equipment and thus the correct size spanner needed to hold it will need to be selected to suit.

Hold the male to male adapter with a spanner whilst removing the Tema coupling.

Remove the Tema coupling and the bonded washer.

Replacement of the Tema coupling is generally the reverse procedure of removal. Always replace the bonded washer with a new one. Upon completion, the joint must be air pressure tested as follows:

Connect a 100 psi air line to the Tema connector. Ensure all burner valves are closed. Apply soapy water to the joints between the valve block and male to male adapter and the male to male adapter and the Tema coupling. If any bubbles are noted, then there is a leak which must be rectified. Correct the leak and re-test.



5.1.7 Male to Male Adapter

To remove the male to male adapter (Item 18, Figure 5.1) from the valve block, proceed as follows:

Remove the male Tema coupling as described in Section 5.1.6 above.

Using an appropriate size ring or open-end spanner, undo and remove the male to male adapter from the valve block.

Replacement is generally the reverse procedure of removal. Always replace the bonded washers with new ones. Air pressure test the joint as described in Section 5.1.6 above.

5.2 Adapter Tubes

The adapter tubes must be replaced if the metal has been dented, if the material shows signs of fatigue, cracking or corrosion, or if the holes for the securing pins have become seriously worn.

Since the adapter tubes are structural, it is recommended that faulty tubes are replaced with new ones, supplied only by the factory.

5.3 Rear Frame Assembly

The rear frame is structural, providing support for the pilot and fuel cylinders. The frame should be considered for repair if the frame tube has been seriously dented, if the material shows any signs of cracking, fatigue or corrosion, if any of the welds show signs of deterioration, or if the frame has become bent or twisted.

Since the nature of the repair cannot be predicted in this manual and since the integrity of the frame is essential to ensure structural continuity, it is recommended that repairs to the frame are only implemented in accordance with a scheme prepared and approved by Lindstrand Balloons Ltd.

5.4 Seat Assembly

Check the seat outer cover for any signs of seam separation, particularly along the front edge. Check the plywood base for any signs of cracking.

It is recommended that repairs to the seat assembly are implemented by replacement of the outer cover or plywood base, as appropriate.

5.5 Pilot Harness

Individual elements (waist straps, shoulder straps and between the leg strap) may be replaced separately or as a whole. Harness stitching may be re-worked if necessary, but must be implemented in accordance with the relevant drawing instructions.

Badly worn or torn webbing must be replaced. This may be done either by removing the old webbing and replacing with new in accordance with the relevant drawing instructions, or by simply replacing the complete strap.

5.6 Fuel System

5.6.1 Fuel Cylinder

Maintenance work required on the fuel cylinder should be in accordance with the requirements of Section 5.3 of the Maintenance Manual.

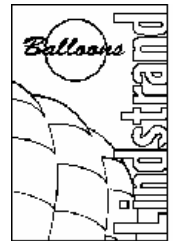

5.6.2 Fuel Connectors

Maintenance work required on fuel connectors should be in accordance with the requirements of Section 5.3 of the Maintenance Manual.

5.6.3 Intermediate Fuel Valve

To remove the intermediate fuel valve (Item 1, Figure 5.2) from the rear frame, proceed as follows:

Using a suitable spanner, undo and remove the two hoses (Items 9 and 10, Figure 3.1) and bonded washers (Item 2, Figure 5.2) attached to the ends of the valve. In order to prevent damage to the brackets supporting the valve, hold the valve with a 22 mm AF open-ended spanner during the operation.

Using a 10 mm open-ended spanner, loosen the two hexagon headed screws (Item 3, Figure 5.2) securing the valve brackets (Item 5, Figure 5.2). Note the orientation of the valve. Slide the two brackets apart and withdraw the valve.

Replacement of the valve is generally the reverse procedure of removal. When replacing the valve, fit new PTFE "O" seals (Item 6, Figure 5.2) in the valve ends prior to re-assembly. Replace the two bonded washers (Item 2, Figure 5.2) prior to re-assembling the hoses to the valve. Note that these washers are of the special self-centering type.

Air pressure test the completed assembly as follows:

Attach a 100 psi air line to the end of one of the hoses. Turn the intermediate fuel valve to the ON position. Apply soapy water to all joints and watch for the presence of any bubbles. If any bubbles form, there is a leak which must be rectified. Continue until all signs of leaking are eliminated.

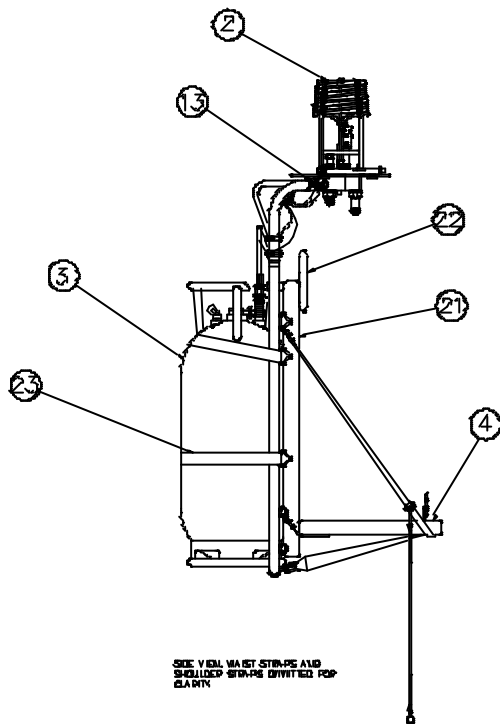

SIDE VIEW WAIST STRAPS AND SHOULDER STRAPS DIVIDED FOR CLARITY

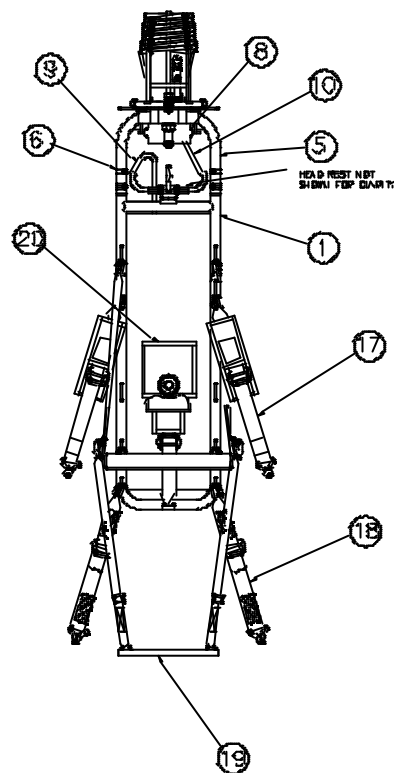

HEAD REST NOT SHOWN FOR CLARITY

215			
214			
213		2	2250 LONG TANK STRAP
212	BA-310-A-010	1	HEAD REST ASSY
211	BA-310-A-024	1	HEAD REST ASSY
210	BA-310-A-017	1	LOWER STRAP ASSY
19	BA-310-A-026	1	FOOT REST ASSY
18	BA-310-A-012	2	WAIST STRAP ASSY
17	BA-310-A-009	2	SHOULDER STRAP ASSY
16			
15			
14			
13		4	40/20 X 12' 10/16" 100% COTTON GENERAL PURPOSE RIGID WEBBING - 100% COTTON
12			
11			
10	BA-310-A-016	1	TANK HOSE ASSY
9	BA-310-A-015	1	TANK HOSE ASSY
8	BA-310-A-016	1	MIRROR ASSY
7			
6		4	40 X 40 100% COTTON RATED 1000 LB WT RIGID WEBBING FOR TIE DOWN
5	BA-310-A-035	2	ADAPTOR TUBE
4	BA-310-A-027	1	BEAT ASSY
3		1	FUEL CYLINDER
2	BLJ-020-A-001	1	CLOUD-HOPPER BURNER CA
1	BA-310-A-025	1	REAR FRAME WELDED ASSY
ITEM	PART No	QTY	DESCRIPTION

FIG 3.1

FI-MM097



LBL HABMM

Issue 1.4

Page S3-9

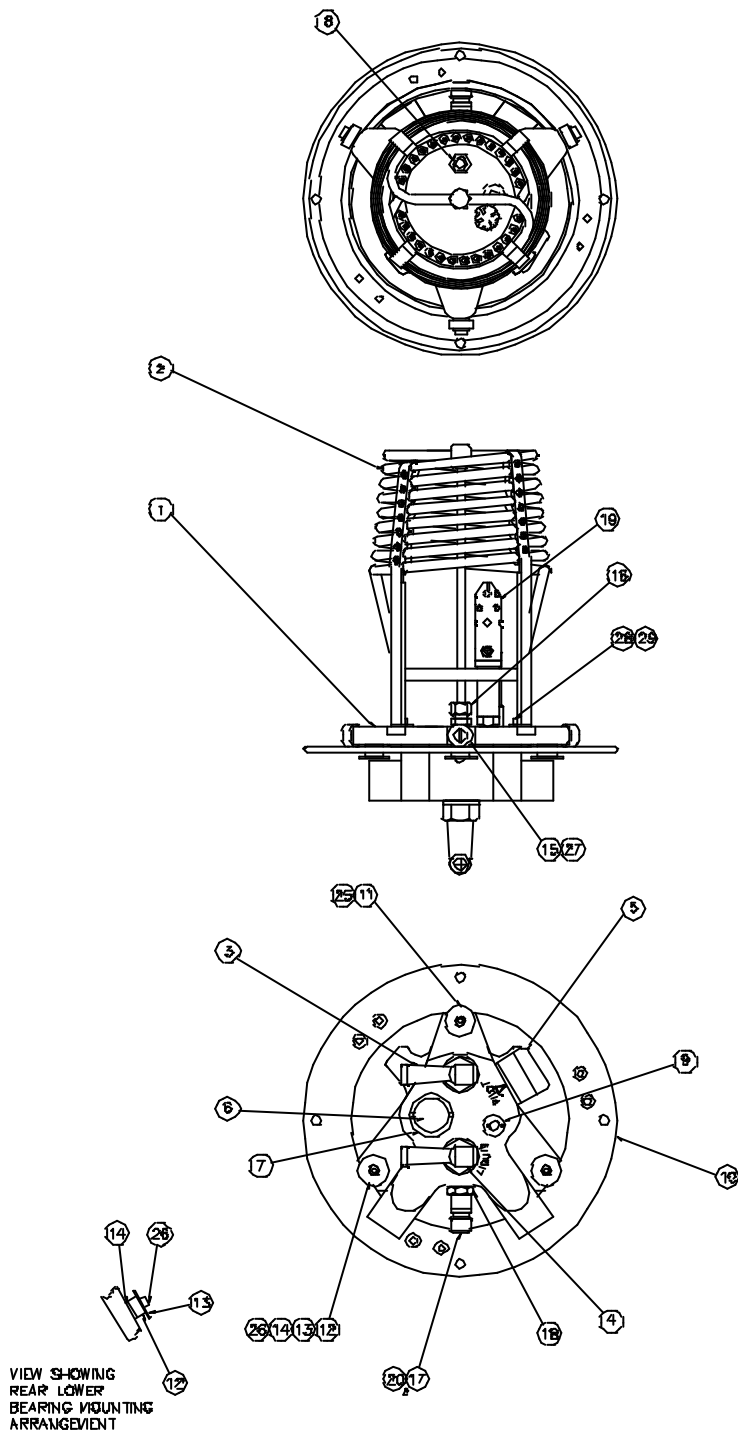

ITEM	DRG/PART No	DESCRIPTION
1	BU-020-A-024	VALVE BLOCK
2	BU-020-A-006	COIL ASSEMBLY
3	BU-008-A-021	LIQUID VALVE ASSEMBLY
4	BU-008-A-022	MAIN VALVE ASSEMBLY
5	BU-002-A-021	REGULATOR ASSEMBLY
6	BU-020-A-018	PRESSURE GAUGE ASSEMBLY
7	BU-002-A-024	PRESSURE GAUGE BEZEL RING
8	BU-020-A-010	LIQUID FIRE ASSEMBLY (HOPPER)
9	BU-020-A-010	CLOUDHOPPER IGNITER ASSEMBLY
10	BU-020-A-025	LOAD RING
11	BU-020-A-026	LOCATION BUSH
12	CH10006	LOWER BEARING
13	BU-020-A-034	RETAINING WASHER
14	BU-020-A-035	BEARING SPACER
15	CH10007	UPPER BEARING
16	---	MALE BULKHEAD COUPLING
17	CY5121	MALE TEMA COUPLING
18	---	3/8" TO 3/8" MALE TO MALE ADAPTER
19	BU-002-A-010	PILOT LIGHT ASSEMBLY
20	CY4129	3/8" BSP NITRILE BONDED WASHER
21	---	---
22	---	---
23	---	---
24	---	---
25	BU2110	1/8" CAP HEAD SCREW
26	---	1/8" CAP HEAD SCREW
27	---	1/8" SLOTTED CHEESE HEAD SCREW
28	BU2082	1/8" CAP HEAD SCREW
29	BU2977	1/8" CRINKLE WASHER
30	BU2211	1/8" PLAIN WASHER

FIG 5.1

FI-MM098

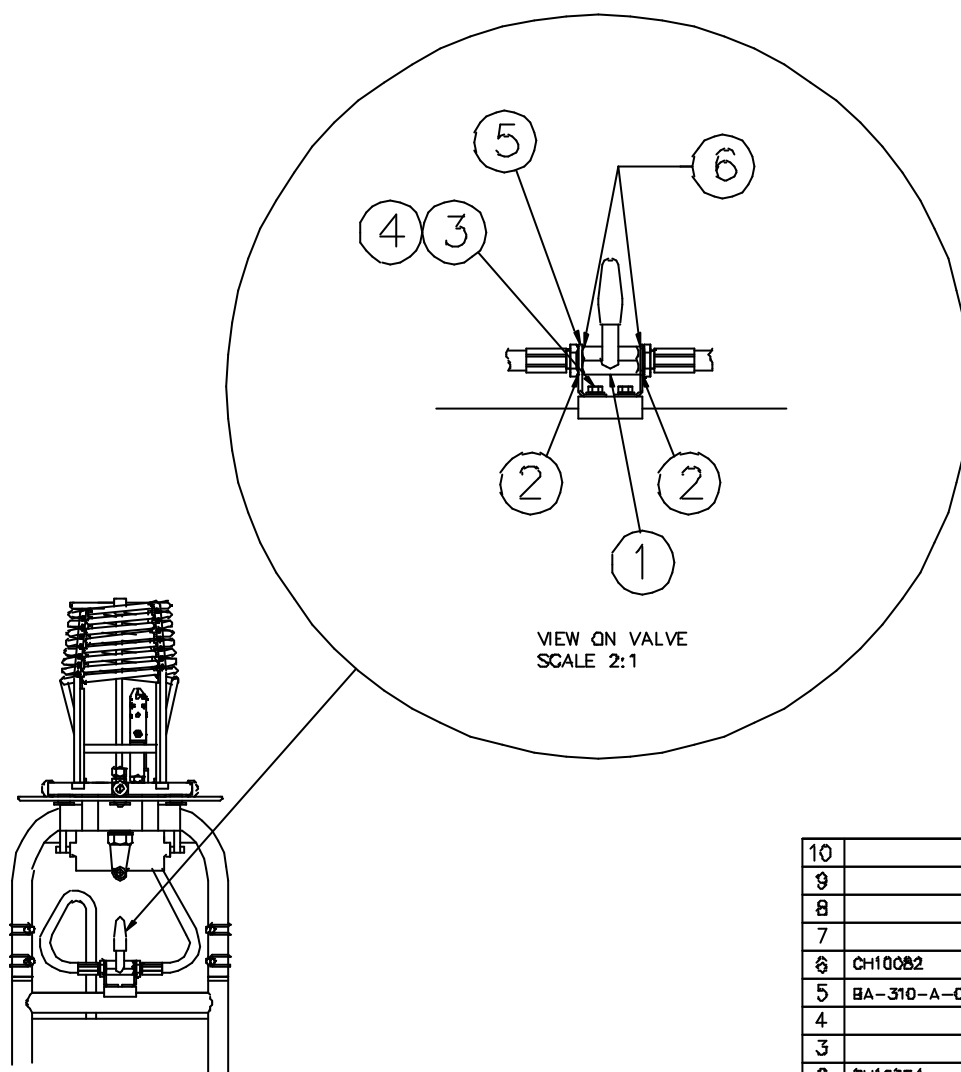

10			
9			
8			
7			
6	CH10082	2	PTFE O SEAL TYPE OR3 PT
5	BA-310-A-053	2	VALVE BRACKET
4		2	1/8" ST SIL PLAIN WASHER TO BS 3692
3		2	1/8" X 8" ST SIL HEX HD SCREW TO BS 3692
2	CH10084	2	3/8" BSP MILD STL ZINC PLATED SELF CENTERING NITRILE BONDED SEAL
1	CH10083	1	3/8" BSP FEMALE / FEMALE ST SIL 1000 LB CLASS BALL VALVE TYPE BV3P
ITEM	PART No	No OFF	DESCRIPTION

FIG 5.2

FI-MM099