



# LINDSTRAND BALLOONS

# FLIGHT MANUAL

For use with all Lindstrand Hot Air Airships

LINDSTRAND BALLOONS  
MAESBURY ROAD  
OSWESTRY  
SHROPSHIRE  
SY10 8ZZ  
TEL: (01691) 671717  
FAX: (01691) 671122

All rights reserved. No part of this manual may be reproduced or transmitted in any form or by any means, electronic, or mechanical, including photocopy, recording, or any information storage and retrieval system, without permission in writing from Lindstrand Balloons, Maesbury Road, Oswestry, Shropshire, SY10 8ZZ, England.



## LINDSTRAND BALLOONS

This Flight Manual has been prepared for the following hot air airship:

Registration: .....

Serial No.: .....

Volume: .....

Type: .....

Build Standard: .....

I hereby certify that this Flight Manual, as prepared for the above airship and incorporating the amendments listed, conforms to the build standard of the above airship at the time of issue of the Certificate of Airworthiness.

Signed: ..... Date: .....

For Lindstrand Balloons

EASA Approval Ref. No. EASA.21J175

### Applicability

This Flight Manual applies to all Lindstrand Balloons Ltd hot air airships. For an explanation of the build standard number see Section 2.2.4.

### APPROVAL STATEMENT

The Civil Aviation Authority of the United Kingdom hereby signifies approval of the data listed in this document. This Flight Manual was first approved on 6 September 1995.

Signed & Sealed





Record of Amendments

No.	Date	Affected Pages	Approval
1	29.03.96	iii, iv, vi, 2, 5, 8, 13, 23, 25, 26, 31, 32	<i>Handwritten signature and date 18/4/97</i>
2	05.01.99	iii, iv, 4, 7, 10, 11, 23, 23a, 24	
3	17-12-09	i,ii,iii,iv,1,2,3,4,7,8,17,18,31,32	EASA Approval EASA.10028378 dated 23rd December 2009

Amendments

This manual is kept up to date by amendments consisting of looseleaf pages, required to add new information or amend existing information. Pages affected by an amendment and the effective date are shown above. The pages themselves are identified by a change of the issue number at the bottom of each page. The number after the point in the issue number represents the amendment level of that page, eg the page marked Issue 1.4 is at Issue 1, modified by Amendment 4. The checklist of pages indicates the issue level of all pages included in this Flight Manual.



Checklist of Pages

Page No.	Issue
i	1.3
ii	1.3
iii	1.3
iv	1.3
v	1.0
vi	1.1
1	1.3
2	1.3
3	1.3
4	1.3
5	1.1
6	1.0
7	1.3
8	1.3
9	1.0
10	1.2
11	1.2
12	1.0
13	1.1
14	1.0
15	1.0
16	1.0
17	1.3
18	1.3
19	1.0
20	1.0
21	1.0
22	1.0
23	1.2
23a	1.2
24	1.2
25	1.1

Page No.	Issue
26	1.1
27	1.0
28	1.0
29	1.0
30	1.0
31	1.3
32	1.3
S1-1 - S1-49	1.0





## CONTENTS

### SECTION 1 - GENERAL

- 1.1 Certification Basis
- 1.2 Change of Ownership

### SECTION 2 - LIMITATIONS

- 2.1 Operational Limitations
- 2.2 Airworthiness Limitations

### SECTION 3 - EMERGENCY PROCEDURES

- 3.1 Burner Failure
- 3.2 Main Engine Failure
- 3.3 Pressurisation Failure
- 3.4 Fire On-Board
- 3.5 Hard Landing Procedure
- 3.6 Unpremeditated Descents
- 3.7 Low Level Obstacles

### SECTION 4 - NORMAL PROCEDURES

- 4.1 Pre-Inflation Checks
- 4.2 Airship Assembly
- 4.3 Inflation
- 4.4 Main Engine Starting
- 4.5 Pre-Flight Checks
- 4.6 Take-Off
- 4.7 Flying
- 4.8 Pre-Landing Checks
- 4.9 Landing
- 4.10 Envelope Deflation

### SECTION 5 - PERFORMANCE

- 5.1 Payload Calculation

### SECTION 6 - WEIGHTS AND EQUIPMENT LISTS

- 6.1 Maximum Weight
- 6.2 Table 1 - Lindstrand Airship Envelope
- 6.3 Table 2 - Lindstrand Airship Gondola
- 6.4 Table 3 - Lindstrand Propane Cylinders
- 6.5 Minimum Equipment List

### SECTION 7 - SYSTEM DESCRIPTION

- 7.1 Envelope
- 7.2 Gondola

### SECTION 8 - HANDLING CARE AND MAINTENANCE

- 8.1 Envelope
- 8.2 Gondola

### SECTION 9 - SUPPLEMENTS

Supplement No. 1 - Engine Information

### SECTION 10 - NIGHT LIGHTING KIT

- 10.1 System Description
- 10.2 Installation
- 10.3 Operation



## SECTION 1 GENERAL

### 1.1 Certification Basis

The certification basis is Draft BCAR Paper No. 696, 27th January 1978, but substituting BCAR 31 in place of BAR's for Manned Free Balloons. For night flying, the airship is illuminated in accordance with the ANO Section 2/15. This Flight Manual provides information for the operation of Lindstrand Balloons Ltd airships in the following categories:

Private  
Aerial Work

### 1.2 Change of Ownership

If the ownership of this airship changes, it is important for the new owner to contact Lindstrand Balloons to ensure that they receive Flight Manual Amendments and Supplements, as appropriate. This can be simply achieved by photocopying Page ii of this manual and writing your name and full correspondence address on the reverse side and sending to Lindstrand Balloons .





#### 2.2.4

#### Build Standard

The Build Standard number is a quick reference number which identifies the various components which make up a particular airship, eg HS-110.001.0

This reference is comprised of three number groups. The first number identifies the airship envelope size and type. In the above example, HS-110 means 110,000 cu.ft. envelope volume of the HS type pattern.

The second number group represents the type of gondola being used. In this case 001 indicates that the two-seater 001 type gondola is being used.

The third number group shows the modification status from the original type design. The number that appears here is the same as the latest applicable modification to the whole airship. If there are no applicable modifications, then 0 is inserted as shown above.



## SECTION 3 EMERGENCY PROCEDURES

### 3.1 Burner Failure

#### 3.1.1 Pilot Light Failure

It is advised that during the flight, each of the burners be used on its' own to ensure that the pilot lights are still alight. If a pilot light does go out, take the following action:

- a.) Continue flying on the second burner.
- b.) Check pilot light valve is on.
- c.) Try re-lightening the pilot lights with electric igniters or the installed piezo electric igniters. If this action is not successful:
- d.) Open the manual burner valve so that there is a small flow of propane through the main jets. Light the propane and hold the valve open to act as a pilot light. Continue burning by opening the valve completely and only closing it enough to retain a small flame. Land as soon as possible.

#### 3.1.2 Main Burner Failure

If one burner stops working, continue to maintain altitude using the other burner. Check the following:

- a.) Pilot light is on and working.
- b.) Check remaining cylinder contents and that cylinder valve and isolator valves are on.
- c.) Open the access hatch and operate the burner using the manual valve.

Land as soon as possible.

### 3.2 Main Engine Failure

If the main engine stops working, then continue to maintain altitude using the burners and check the following:

- a.) Rotax circuit breaker in and main power switch on.
- b.) Sufficient petrol remaining in fuel tank and petrol valve on.
- c.) Go through start-up procedure as specified in Section 4.4, with the exception that if the engine is still hot, then the choke should not be used, as this will cause engine flooding.

If the engine fails to restart, then the airship can be flown like a balloon. In this situation, keep the pressurisation engine running in order to supply fresh air to the burners and to keep the fins rigid. Use the rudders to keep the nose pointing into wind. Land as soon as possible.

### 3.3 Pressurisation Failure

This can be caused in two ways. Either air is being lost too quickly from the envelope, or the pressurisation fan has stopped working.



### 3.3.1 Air Loss

- a) Check to see if the deflation panels are closed.
- b) Check that pressure relief valves are working correctly.
- c) Visually inspect the envelope by looking through the access hatch. Look for holes in the envelope, especially in the upper half.

If the envelope is losing air, it is unlikely that the problem can be resolved in flight. Consequently, keep the pressurisation engine running as fast as possible, and continue burning in order to replace the lost air. The main thrust engine should be reduced to idle but kept running. This allows the engine to be used carefully during the landing stages to assist in achieving the best landing. However, it should be noted that prolonged use of the engine will tend to increase the pressure loss inside the envelope and so should be avoided. Land as soon as possible.

### 3.3.2 Pressurisation Fan Failure

If the pressurisation fan stops working, then check the following:

- a) Sufficient fuel remaining.
- b) Fuel shut-off valve is open.
- c) Honda and pump circuit breakers are in.
- d) Try to re-start the engine.

If the engine cannot be restarted, then continue to fly using the burners and main engine. Land as soon as possible.

### 3.4 Fire On-Board

Locate the source of the fire and identify the type of fire. Isolate the supply of fuel to the fire. A fire extinguisher is located under the port (left hand) seat. Aim the extinguisher at the base of the fire and put the fire out. Assess the damage and isolate any damaged components. Land the airship as soon as possible.

If either of the engines suffers a fire, then take the following action:

- a) Turn off petrol supply to the engine on fire.
- b) Continue to run the engine at the maximum throttle setting until it stops.
- c) Operate the fire extinguisher to put out fire whilst running engine.
- d) Land as soon as possible.

### 3.5 Hard Landing Procedure

Hard landings may be separated into heavy landings and fast landings.

#### 3.5.1 Heavy Landings

Heavy landings are landings made at a high rate of descent due to total burner failure or major loss of lift. Prepare for heavy landings as follows:

- a) Ensure harnesses are tightly secured.



- b) Close gas valves and vent propane lines if burner is completely unserviceable.
- c) Leave pressurisation fan running.
- d) Use main engine and rudders to avoid obstacles on approach.
- e) Turn both engines off prior to touchdown.
- f) Once ground contact is imminent, pull the deflation rip panels and keep open until airship has stopped moving.
- g) Exit gondola once there is no likelihood of the airship moving.

### 3.5.2 Fast Landings

These are landing which may arise from a significant increase in windspeed during flight, or a failure of the main engine. Prepare for fast landings as follows:

- a) Ensure harnesses are tightly secured.
- b) Use main engine (if working) to fly airship into wind as fast as possible.
- c) Use the burners to control height and make an approach heading into wind all the time.
- d) Keep pressurisation engine running during approach to assist with steering.
- e) Turn off both engines if working, prior to touchdown. Turn off main power.
- f) Operate rip panels and wait until airship comes to a rest.

### 3.6 Unpremeditated Descents

A descent which results from extreme downdrafts or thermic activity, should be halted by using the burner. All available power should be utilised. A safe landing should be made as soon as possible.

If the descent is a result of a total burner failure or fuel exhaustion, then the descent cannot be stopped. Any available ballast, such as trail ropes, may be jettisoned provided that to do so will not endanger persons on the ground. The occupants should be briefed for a heavy landing, as described in Section 3.5.1.

### 3.7 Low Level Obstacles

Care must be used when flying close to the ground, in order to anticipate and correct changes in flight direction which could cause a collision. It is important to make the decision to ascend or descend and keep to the decision. It is always better to maintain or increase a vertical direction of motion than to reverse it.

### 3.8 Low Voltage Warning

If the low voltage warning light illuminates during flight, take the following action:

- a) Ensure that the two circuit breakers for the two alternators are fully depressed.
- b) Turn off all electrical equipment which is not necessary for flight.
- c) Land as soon as possible. There should be sufficient power in the battery for 40 minutes of flight.



## SECTION 4 NORMAL PROCEDURES

### 4.1 Pre-Inflation Checks

#### 4.1.1 Main Engine Checks

Prior to conducting any operation of the main propulsion engine, it is essential that the ground crew have been correctly briefed as to their duties and that they are made fully aware of the dangers of the propeller.

- a) Check ignition and main power switches are off.
- b) Check petrol contents. Remove petrol tank and empty of contents. Re-fill with a minimum of 10 litres of uncontaminated, clean 90 RON petrol (unleaded). Open petrol shut-off valve. Check for any leaks and for worn or chaffed hoses.
- c) Check visually for any coolant leaks and ensure sufficient coolant in reservoir.
- d) Check oil injection tank contents. Re-fill with Castol TTS fully synthetic two-stroke oil. This is the only approved oil.
- e) Check spark plug caps for security.
- f) Visually check engine and gearbox for oil leaks.
- g) Check engine and gearbox for loose or missing nuts and bolts. Also check engine mountings for security.
- h) Check propeller for splits or chips and check propeller mounting.
- i) Check that throttle and choke movement is free and full.
- j) Check exhaust mountings and ensure there is no damage.
- k) Check oil level in rotary valve lubrication tank. Fill with Castol TTS (130 cc).
- l) Start engine following the procedure in section 4.4, and check for clean running.

#### 4.1.2 Pressurisation Engine

- a) Check fuel contents in the main petrol tank is greater than 10 litres. Fill with 90 RON unleaded if required. Open petrol shut-off valve.
- b) Check engine mounting bolts and main frame mountings.
- c) Check security of coupling locking wire.
- d) Rotate fan by hand to ensure that the fan is clear of the guard and that the blades are not damaged.
- e) Check throttle movement is free.
- f) Remove locking pip pin and move throttle fully forward to turn choke on. Close the miniature circuit breakers marked HONDA and PUMPS
- g) Start engine and once warm (after 5-10 seconds), gradually close choke lever and replace pip pin.
- h) Run engine through to maximum power and ensure once at idle that the stop switch stops the engine.



#### 4.1.3 Propane Cylinders

- a) Ensure sufficient fuel is available for projected flight. Fuel for burners is water free LPG.
- b) Ensure cylinders are correctly located and all three cylinder straps per cylinder are tightened.
- c) Connect propane hoses and ensure burner valves are all off.
- d) Make electrical connections to fuel gauge senders.
- e) Open the liquid valves to pressurise the fuel system and check each gas joint for leaks. Also check the hoses for signs of wear or chaffing.
- f) Check fuel pressure by looking at the pressure gauges on the burners. Ensure that the minimum operating pressure is exceeded (min. pressure 5 bar (75 psi)).

#### 4.1.4 Burners

- a) Rotate the burners so that they are in the flight position. Secure in place with the larger pip pin.
- b) Remove the upper small pip pin and check free movement of the burners.
- c) With fuel supplied to the burner, turn the pilot light valves on and ignite using the piezo igniters. Shut the pilot lights off and repeat the above test with the electric ignition system.
- d) Open the burner control hydraulic isolator valves on the centre console so that they are in line with the hose.
- e) With the burners locked in the upright position, test fire each burner. Check for leaks in the complete system.
- f) Repeat the above test, but operating the burner controls using the hydraulic remote handles.

### 4.2 Airship Assembly

#### 4.2.1 Positioning

When removing the gondola from the transportation vehicle, be careful to avoid damaging the transponder and VHF aerials and the anti-collision strobe light. All these items are located on the underside of the gondola.

The gondola should be pointed in a direction which is approximately 5° to the right of the wind direction. This ensures that the wind tends to keep the airship envelope on the right hand side of the gondola during the inflation stages. The burner is intended to be tilted to the right hand side for inflation.

#### 4.2.2 Laying Out

Position the envelope bag on the right of the gondola and unpack the envelope with the nose generally pointing into wind.

Connect the carabiners on each of the catenaries' tapes groups to the respective suspension points. This process is best achieved with the burner rotated down into the gondola in its transport position. Ensure that the carabiners are not twisted and that the screw gates are closed. Connect the eight French hooks on the envelope to the rings on the upper frame of the gondola. There are three on each side and one both at the front and rear.

Connect the envelope pressure gauge feed tube onto the connector which is situated on the envelope lower surface, just behind the front windscreen.



Connect the pressurisation system feed tube onto the cowling of the fan by applying the six French hooks onto the D-rings and tightening the friction straps around the circumference of the cowl. This task is sometimes easier once there is some cold air in the envelope.

Connect the two rudder control lines and the rip panel operating lines into the gondola. All of these lines exit the envelope through reinforced holes on the lower surface, just behind the front windscreen. Attachment lugs are positioned on the lower windscreen former.

If navigation lights are fitted to the envelope, then connect the power lead for the navigation lights into the socket which is mounted on the upper gondola cross bar.

### 4.2.3 Sealing the Envelope

#### 4.2.3.1 Inflation Tube

Remove the cover patch on the inflation tube by unclipping the two French hooks and peeling open the velcro. Open the inflation tube drawstring and insert the end of the fan tube into the inflation tube. Connect the four French hooks on the end of the fan tube onto the cross tapes inside the inflation tube. Seal the velcro of the inflation tube onto the fan tube.

#### 4.2.3.2 Cold Air System

Enter the airship envelope through one of the open dump panels. Locate the toroidal distribution tubes in the tail section and seal the velcro deflation slits. There are four internal slits, one situated in the middle of each of the distribution tubes.

Lay the fins out and locate the top fin and rudder.

Seal the three deflation slits which are located on the top edge of the fin, the rear edge of the rudder and the lower edge of the rudder. The lower fin and rudder deflation slits are identical to those on the top fin. The two horizontal fins also have three deflation slits situated on the outermost edge.

#### 4.2.3.3 Deflation Panels

Pull the rip lines back towards the panels until all the slack is inside the envelope, ensuring that there are no knots or tangles in the lines.

Seal both of the rip panels by getting two people to stretch both the envelope and rip panel edges. Align the velcro seal and press firmly together. Continue this process until all sides of the panel are sealed. The resulting joint is inspected to ensure that there are no puckers or wrinkles. The rip locks are fastened from inside the envelope. There are two rip locks for each dump panel. Once the rip panels have been sealed, the remaining slack in the rip lines should be pulled back to the panels to ensure that the rip panels are not inadvertently opened during inflation. This also serves to ensure that there are no tangles in the lines.

## 4.3 Inflation

### 4.3.1 Inflation Restraints

In calm conditions, the airship can be restrained during the inflation by tying the nose line to a vehicle. The vehicle should be placed directly in line with the gondola, because this will permit the envelope to rotate upright once it has sufficient lift.

In more windy conditions, it is advisable to also tether the gondola using a vehicle placed alongside the gondola and facing it. The restraint rope should be attached to the closest two gondola suspension points, in a V configuration.



#### 4.3.2 Cold Inflation

Start the inflation fan and allow the envelope to fill. Enter the envelope through either of the pressure relief valves and perform an internal check as follows:

- a) No damage to any fabric or load tape.
- b) Check catenaries for burn damage and ensure that they are not twisted.
- c) Ensure rudder and rip lines are not tangled or frayed.
- d) Inspect envelope penetration holes for wear.
- e) Check that navigation light leads are not tangled (if fitted).

Once the envelope has started to fill, the pressurisation engine may be started to help speed up the filling process.

#### 4.3.3 Hot Inflation

Once the main envelope is completely filled with cold air, then the hot inflation may begin.

Firstly erect the burner and lock it into the flying position if this has not yet been done. Zip the access hatch completely closed and seal the velcro around the burner support tube and feed hoses. Unzip the hatch sufficiently for the pilot to gain access, by standing on the left hand seat (port seat).

It is normally best for the pilot to sit on the port (left) side of the top frame, behind the burners for inflation.

Unpin the upper swivel block and tilt the burners over to the starboard (right) side so that they point between the catenary tapes. Turn on the propane cylinders both at the cylinder and at the isolator valves. Turn on the pilot lights, and ignite. Shut down the pressurisation engine completely before commencing hot inflation. This prevents the pressure feed tube from being damaged.

Use the rear burner to inflate the airship. It is best to use short burns with long pauses between, to allow the hot air to mix throughout the envelope. It is inadvisable to use the front burner during the early stages of inflation, because the envelope skin is too close.

As the envelope heats up, it will lift off the ground and slowly rotate until it sits above the gondola. During this phase, the burners must be tilted back towards the vertical to avoid burning the catenaries.

Once the envelope is upright, the burners upper swivel block is locked into the vertical position by inserting the pip pin through the swivel block. The pilot can now exit the envelope and seal the window hatch by zipping it up. The forward or rear burners can now be used to level the airship and to increase the envelope pressure. The pressurisation engine should now be restarted.

It should be noted that whenever the burners are used whilst the airship is in contact with the ground, the pilot must check to ensure that the catenaries are not in the path of the burner frame. This is achieved by looking up into the envelope through the window. Once in flight, the gondola will naturally align with the catenaries and this check is not necessary.

Once the airship has been fully sealed and the pressurisation engine and burners are operating, the envelope pressure gauge must be monitored to ensure the maximum pressure is not exceeded. The airship should now be heated until it is just buoyant. This allows the ship to weathercock.



The inflation fan may now be turned off and the fan tube disconnected. Once the tube has been released, pull the drawstring tight and seal off the inflation tube securely. Clip the cover patch in place and seal the surrounding velcro strips.

#### 4.4 Main Engine Starting

It is best to start the main engine once the airship has risen clear of the ground, if the engine has been test run previously and no problems were discovered. This maximises the ground crew safety. However, the following checklist is for ground starting of the main engine:

- a) Turn on the main power switch if it is not already on.
- b) Ensure that there is sufficient fuel in the petrol tank and that the stop valve is open. This is located behind the pilots' right shoulder (left hand seat). When the valve is ON, the handle is aligned with the fuel line and valve.
- c) Close the miniature circuit breakers which are marked PUMP, ROTAX and FLYDAT by pushing the buttons in.
- d) If the engine has not been test run, wait for 5 seconds to allow the pumps to prime the fuel system.
- e) Pull the Rotax choke lever situated between the two seats backwards, towards the engine and hold in that position.
- f) Do not open the throttle at all, because this will flood the engine.
- g) Get a crew member to observe behind the gondola, that the protective boots have been removed from the propeller and that the propeller is clear.
- h) Turn the ROTAX START key around to the "START" position and hold there until the engine fires. Once the engine fires, turn the key back to the "BOTH" position.
- i) After 2 or 3 seconds move the choke lever so that it is fully forward and open the throttle by moving the Rotax throttle lever forward slightly.
- j) Move the throttle lever until the engine speed readout on the Flydat unit shows 3000 rpm. Turn the starter key firstly to the "L" position and watch the engine speed. The revs should not drop more than 300 rpm. Turn the key to the "R" position and again watch the engine speed. Turn the key back to the "BOTH" position.
- k) Once the engine is idling smoothly, close the two circuit breakers which isolate the two alternators. These are situated in between the two seats towards the rear of the centre panel.

#### 4.5 Pre-Flight Checks

- a) Rudder operation satisfactory.
- b) Main engine working.
- c) Pressurisation engine working and locking pip pin inserted in plate.
- d) Rip panels secured and locked.
- e) Both pilot lights alight and burners working.
- f) Tail line released.



- g) Flytec instrument on and envelope temperature readout received.
- h) Pressure gauge connected and working.
- i) Inflation tube sealed and covered.
- j) Pressure relief valves working.
- k) QNH/QFE set as appropriate.
- l) Maps present for flight.
- m) Gross weight for conditions not exceeded.
- n) Paperwork present and correct.
- o) Fire extinguisher installed and full.

#### 4.6 Take-Off

Gradually heat the ship until it rises, keeping the nose into wind. Signal the ground crew to bring in the nose line and to store it in the gondola. Once clear of the ground, increase the thrust from the main engine slowly, to increase the airship speed.

#### 4.7 Flying

The airship is controlled in flight in three different ways:

##### 4.7.1 Main Thrust Engine

This engine provides the main forward thrust for the airship via the propeller. Power should always be increased slowly to minimise the nose pitch up tendency.

##### 4.7.2 Burners

The burners control the static lift of the airship by varying the density of the hot air.

##### 4.7.3 Rudders

The rudders control the airship in yaw. Pulling the green line causes the nose of the airship to move to the right (starboard). Pulling the black line causes the nose of the airship to move to the left (port).

##### 4.7.4 Pressurisation System

The pressurisation engine indirectly has a significant effect on the control of the airship. The pressurisation fan supplies cold air into the tail control surfaces, including the rudder. Consequently, if the pressure delivery is inadequate, the response from rudder movements tends to be slow. The pressurisation engine also supplies fresh air to the burners. This has a side effect of pressurising the main envelope. With high internal envelope pressure, the airship is capable of higher forward speeds before nose indentation begins.

It should also be noted that operating the burners in an enclosed envelope, also tends to increase the envelope pressure. Consequently, the balance between envelope temperature and pressure must be fully understood for a pilot to utilise the airship to its' full potential.



#### 4.7.5 Aerodynamic Lift

This is the lift force that is generated by the airship pushing its way through the air. The amount of lift is largely dependent upon the speed and attitude of the airship at any time. What is important to note is that as forward speed is reduced, it may be necessary to increase the heat inside the envelope to compensate for a reduction in aerodynamic lift.

#### 4.8 Pre-Landing Checks

Landing sites should be found when the fuel cylinders are both registering less than 35%.

- a) Over-fly the landing site and carefully observe the surface for indications of ground wind and for any downwind obstacles.
- b) Inform the ground crew of your intentions.

#### 4.9 Landing

Perform the approach and landing with the nose of the airship facing into wind. This allows the thrust engine to be used to balance the airship against the wind, consequently reducing the airships' speed over ground.

The ground crew play an important part in the airships' landing. One crew member should be instructed to retrieve the nose line and any other crew briefed to stop the forward movement of the gondola.

It is important to ensure that the envelope pressure and the tail fins pressure is kept high during landing. This is so that the airship has maximum manoeuvrability from the rudders during the landing.

During the landing approach it is important to remember to avoid any downwind obstacles, especially with the tail line which is hanging free.

Just prior to touchdown, shut down the main engine. This avoids accidental damage to the propeller, as well as being much safer for the ground crew.

#### 4.10 Envelope Deflation

- a) Turn off the pilot lights and ensure flame has extinguished.
- b) Vent propane through the burner coils to cool them.
- c) Turn off propane cylinders and vent the propane lines.
- d) Turn off the pressurisation engine and shut off petrol supply to the engine.
- e) Close the petrol valve.
- f) Pull out all circuit breakers and turn off main power switch.
- g) Open the hydraulic isolators on the centre console.
- h) Turn off Flytec instrument.
- i) Pull deflation panels until completely open.
- j) Disconnect rudder lines, envelope pressure gauge and navigation lights connector if fitted.

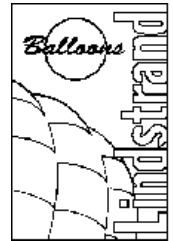

- k) Disconnect air pressure feed tube from pressurisation tube.
- l) Open all deflation vents in tail fins (21 internal and external vents).
- m) Once the envelope is partially deflated and secured at the nose, the four carabiners may be disconnected from the gondola.
- n) Remove all remaining air by squeezing out of the tail section.



## SECTION 5 PERFORMANCE

### 5.1 Payload Calculation

The payload weight that is available on a certain day depends upon the gross lift. The gross lift varies with the ambient temperature and the intended maximum altitude. The effect of these two factors can be assessed, and the gross lift calculated by using the universal load chart and table. The following example is conducted in metric units. The charts are based on an internal envelope temperature of 100°C (212°F) and on International Standard Atmosphere (ISA). This consists of an ambient temperature of 15°C (59°F), 1013.2 millibar (29.92 in.Hg) and an air density of 1.225 kg/m<sup>3</sup> (0.07647 lb/ft<sup>3</sup> or 0.002377 slug/ft<sup>3</sup>). Temperature correction curves are also provided for convenience.

#### Example 1 - Metric Units

Airship Size:	Lindstrand HS-110 (3114 m <sup>3</sup> )
Maximum Altitude:	Sea level to 1000 m
Ambient Temp:	16°C
Fuel Carried:	2 V40 cylinders full @ 60 kg each = 120 kg 1 petrol tank @ 22 kg full
Empty Gondola:	294 kg
Envelope:	285 kg

Using the metric universal load chart, first find the correct ambient temperature along the horizontal scale. Follow a line up vertically, until it intersects with the sea level curve. Draw a line with the same curvature as the ISA temperature correction curve downwards, until it intersects the 1000 m altitude line. From this point, follow the lines across horizontally, back to the vertical scale. The reading of 0.267 obtained, gives the gross lift per cubic metre.

If this figure is then multiplied by the airship volume in cubic metres, which can be found in Table 1, Section 6.2, the result is the gross lift for the predicted flight plan. Whatever the resulting gross lift is calculated to be, it cannot be greater than the Maximum Weight for each given airship size. For convenience, a ready reckoner table is provided for the universal load chart, in order to convert the lift per unit volume into a gross lift figure.

In this example, the gross lift for the flight plan is:

$$0.267 \times 3114 = 831 \text{ kg}$$

The payload is established by subtracting the empty weight from this figure:

$$831 - 294 - 285 - 120 - 22 = 110 \text{ kg}$$

The total weight of the occupants must not exceed this figure of 110 kg. This means that with an average weight of 77 kg, one seat can be occupied.

## METRIC UNIVERSAL LOAD CHART

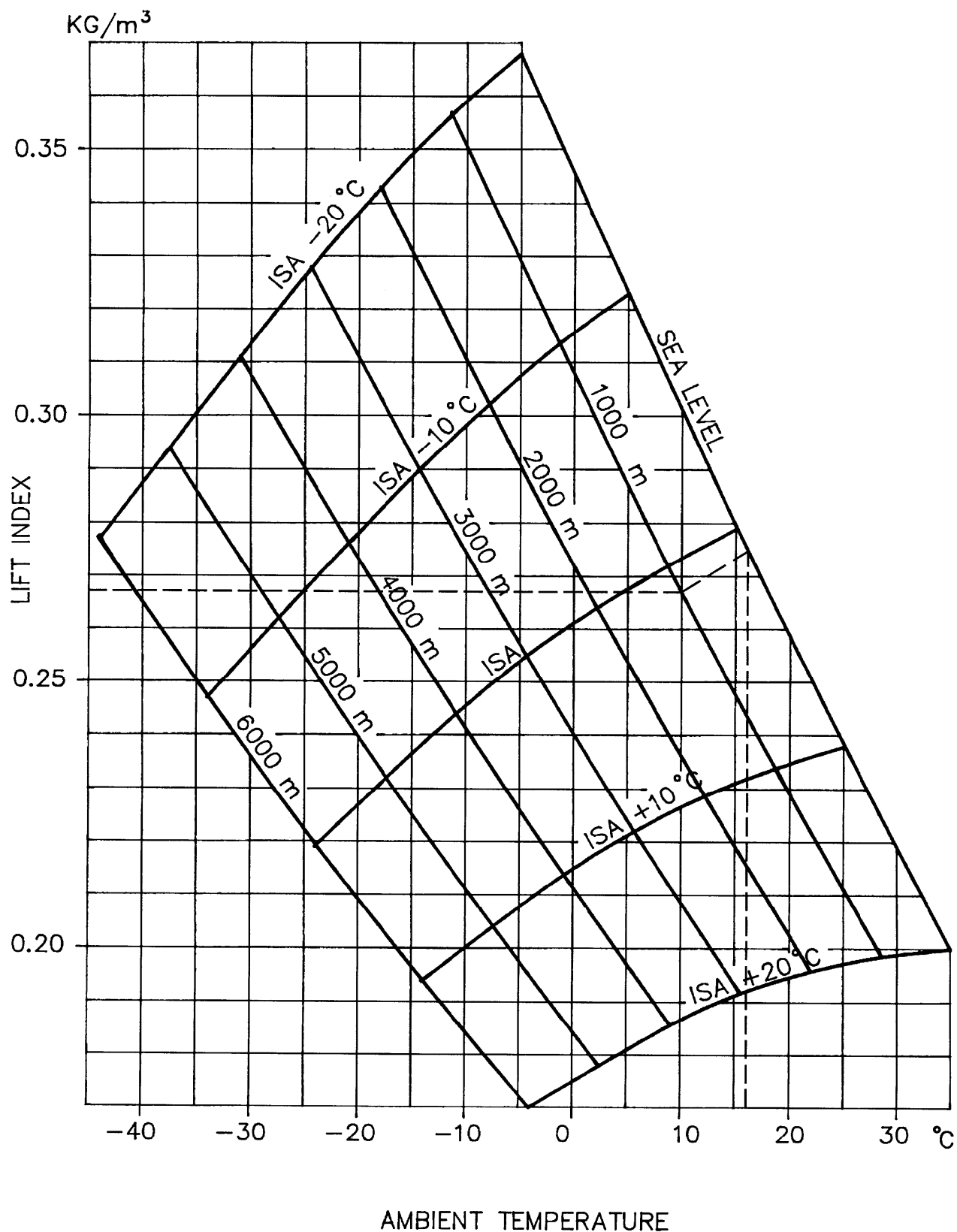



METRIC LIFT READY RECKONER

LIFT INDEX kg/m <sup>3</sup>	ENVELOPE VOLUME CUBIC METRES (CU.FT./1000)	
	314 (110)	398 (120)
0.170	529	577
0.175	545	594
0.180	560	611
0.185	576	628
0.190	592	645
0.195	607	662
0.200	623	679
0.205	638	696
0.210	654	713
0.215	669	730
0.220	685	747
0.225	701	764
0.230	716	781
0.235	732	798
0.240	747	815
0.245	763	832
0.250	778	849
0.255	794	866
0.260	810	883
0.265	825	900
0.270	841	917
0.275	856	934
0.280	872	951
0.285	887	968
0.290	900	985
0.295	900	999
0.300	900	999
0.305	900	999
0.310	900	999
0.315	900	999
0.320	900	999
0.325	900	999
0.330	900	999
0.335	900	999
0.340	900	999
0.345	900	999
0.350	900	999
0.355	900	999



**SECTION 6**  
**WEIGHTS AND EQUIPMENT LISTS**

**6.1 Maximum Weight**

The Maximum Weight (MW) is the figure used in the design and certification of the envelope and gondola and this weight must never be exceeded. The Maximum Weights for all Lindstrand Balloons Ltd airships are tabulated below:

**6.2 TABLE 1 - LINDSTRAND AIRSHIP ENVELOPES**

Airship Type	Volume		FAI Class	Maximum Weight		Envelope Weight	
	cu.m.	cu.ft.		kg	lbs	kg	lbs
HS-110	3114	110,000	BX5	900	1980	285	627
HS-120	3398	120,000	BX5	999	2198	324	713

**6.3 TABLE 2 - LINDSTRAND AIRSHIP GONDOLAS**

Two-seat gondola

Gondola Type: 001

Gondola Weight (dry): 294 kg

**6.4 TABLE 3 - LINDSTRAND PROPANE CYLINDERS**

Cylinder Type	Empty Weight		Fuel Capacity		Full Weight	
	kg	lbs	kg	lbs	kg	lbs
Worthington	14	31	20	44	34	75
V20	14	31	20	44	34	75
V30	18	40	30	66	48	106
V40	20	44	40	88	60	132

**Notes**

- a) Any fuel cylinder can be used within the gondola, provided that the liquid withdrawal connectors are compatible and that a minimum of two full cylinders are present.
- b) Both master and standard configuration of fuel cylinders may be used within the gondola.
- c) The standard cylinder fitment is 2 V40 cylinders.

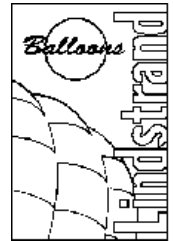

### 6.5 Minimum Equipment List

The minimum equipment list describes the minimum equipment necessary for flight:

- a) Two LPG flight cylinders with the correct hose connections.
- b) Fire extinguisher.
- c) Leather gloves.
- d) A serviceable envelope temperature gauge.
- e) A serviceable envelope pressure gauge.
- f) A separate means of lighting the pilot lights.



## SECTION 7 SYSTEM DESCRIPTION

### 7.1 Envelope

The airship envelope, shown in Figure 7.1, is a development of a hot air balloon which has a length to height ratio of 2.8:1 and is fitted with four tail stabilisation surfaces. The main lifting volume of the envelope is constructed from panels of high strength, high tenacity nylon, which is coated with a silicon elastomer co-polymer to provide sealing. The panels are joined using the established fell seam and every seam on the main envelope is also reinforced with a polyester load tape. The envelope is separated into longitudinal gores which extend from the nose to the tail. Each gore is constructed from several panels. The envelope is fitted with two longitudinal catenaries which transmit the flight loads into the envelope skin. The gondola is also suspended from these catenaries by four carabiners, one in each corner of the gondola.

The tail is arranged in a cruciform layout with the two vertical fins also carrying a full depth rudder. The complete tail structure is inflated with cold air which is supplied from the gondola. A single feed tube begins at the gondola and leads back into a toroidal distribution system. From these pressure tubes, each fin and rudder is supplied with cold air.

The rudders are controlled together by a series of lines which attach the rearmost edge of the rudders to the gondola. These lines pass through the skin of the envelope and finally exit the envelope just above the gondola. Pulling on these lines in the gondola cause the rudder to be displaced and the airship to turn. The two ropes in the gondola are coloured green and black. Pulling the green lines causes the nose of the ship to move to the right. Pulling the black rope causes the nose to move to the left.

Final deflation of the envelope is achieved by operating two rip panels which are located either side of the uppermost fin. The control lines are attached to the rearmost edge of the rip panels and run forward, through pulleys, until they exit into the gondola. Pulling on these two lines cause the four rip locks to release and then the panels are opened forwards. The two rip panel control lines are red in colour.

The main envelope is also fitted with two fabric pressure valves. These valves open at approximately 5 mm water gauge to release internal air. They are positioned on the lower surface of the ship just in front of the gondola, thus allowing their operation to be monitored by the flight crew.

For night flying operations, the envelope is also fitted with the following navigation lights:

Nose	-	White light
Tail	-	White light
Port Fin Tip	-	Red light
Starboard Fin Tip	-	Green light
Anti-Collision Light	-	Red flashing light

Nose and tail control ropes are fitted onto the aluminium end rings to assist in the inflation stages and to aid ground handling.

Cold air inflation is achieved through an auxillary inflation tube which is situated on the lower envelope surface between the two pressure valves.

### 7.2 Gondola (see Figure 7.2)

#### 7.2.1 Space Frame

The space frame is constructed from square section tubular stainless steel, and it provides a support for all the necessary fuel, equipment and crew. The crew are seated side by side in the forward portion of the gondola and are provided with safety harnesses for their security.

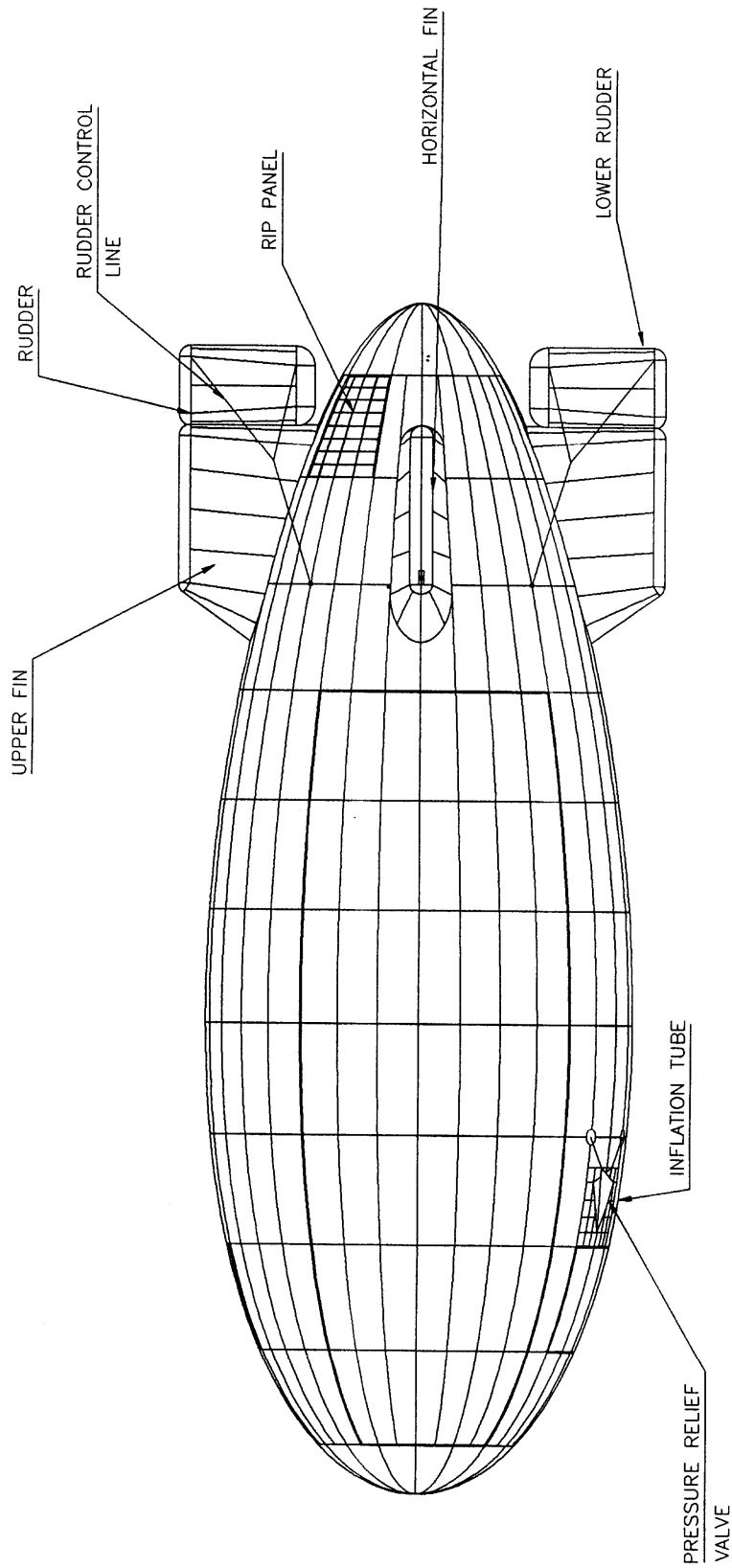

FIG 7.1 HOT AIR AIRSHIP ENVELOPE

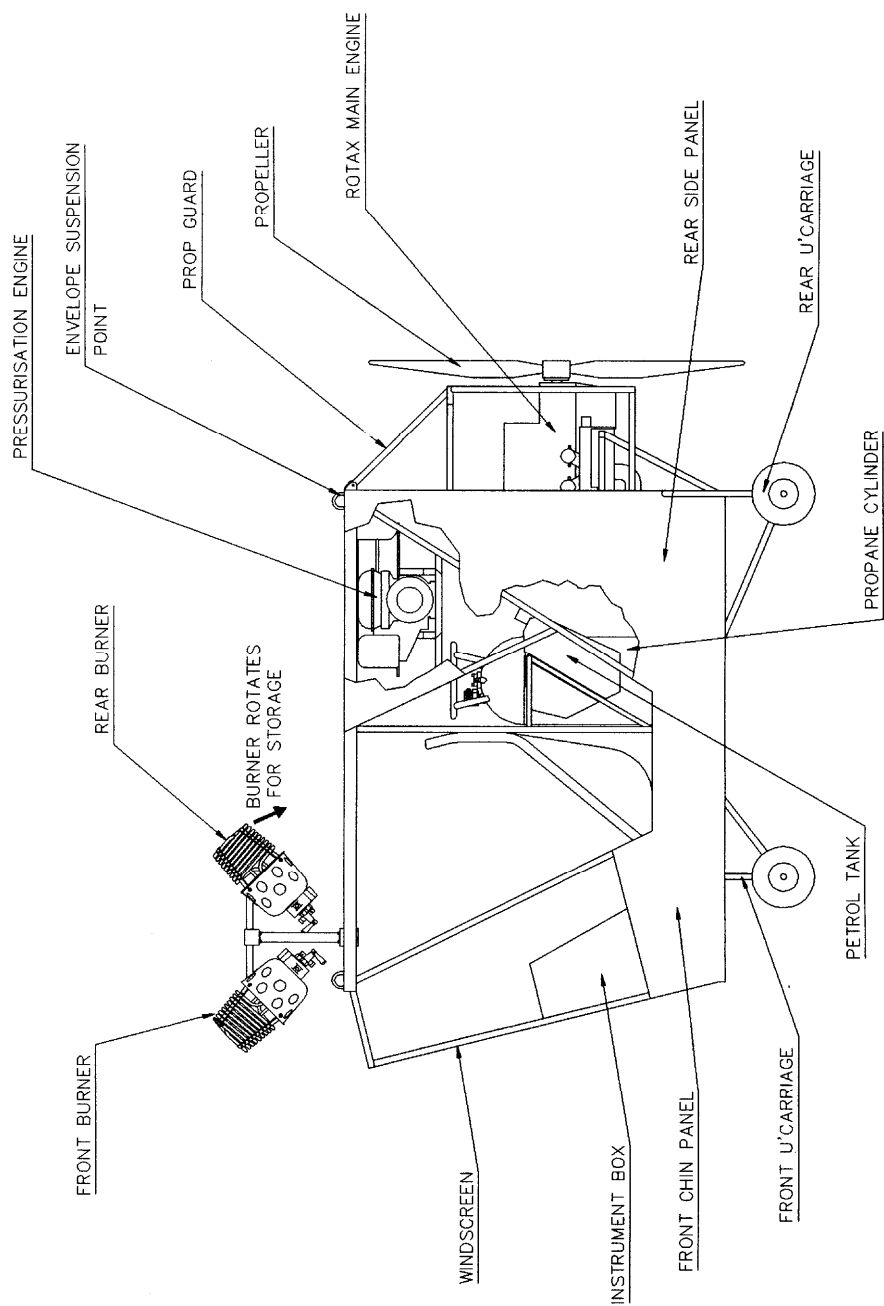

FIG 7.2 GONDOLA



The front portion of the gondola is covered with a polycarbonate windscreen. The remainder of the gondola is covered with one forward lower glass reinforced plastic panels.

The front crew cabin floor is created by covering the framework with aluminium sheets. Two propane fuel cylinders are retained in position by standard cylinder straps behind each of the crew seats. Inbetween the two propane cylinders is situated a petrol tank.

The undercarriage is laid out in the shape of a trapezoid, with the track of the front wheels narrower than that of the rear. All wheels are fixed in the forward/rear direction.

### 7.2.2 Propulsion Engine

The thrust power for the airship is provided by a Rotax 582 twin cylinder, two stroke, dual ignition water cooled engine. This drives a four bladed fixed pitch Arplast 60" propeller in the pusher configuration, via a reduction gearbox. This propeller is used to achieve low noise. The propeller is guarded on the left and right hand sides by a tubular steel propeller guard. In addition, the rear undercarriage wheels are outboard and forward of the propeller resulting in the wheels contacting objects before the propeller does.

The engine may be fitted with just one forward 12 V alternator 155 W, which is mounted directly onto the forward end of the crankshaft. This provides all the necessary power for the flight controls and instrumentation. Alternatively, if the night flying kit is included, then an extra rear 12 V alternator 230 W is added onto the engine to supply sufficient power to run the navigation lights. With both alternators fitted, there is also a large amount of duality for safety.

### 7.2.3 Pressurisation System

The pressurisation system is situated in the rear upper section of the gondola. It consists of a 5.5 HP four stroke Honda petrol engine, which drives a ten blade pressurisation fan through a shaft coupling. All of the above components are mounted within a stainless framework which itself is mounted on the main gondola structure through anti-vibration mountings. The engine is provided with an electric starter motor and a remotely controlled throttle lever, so that the engine can be controlled from a seated position.

The throttle lever is situated on the starboard side of the main engine throttle lever and has a two-stage operation. The majority of the lever movement controls the engine speed. The forwardmost portion of the movement is the engine choke position. To prevent the choke being selected inadvertently, a locking pip pin is inserted across the path of the levers' movement. This pin must be removed in order to obtain the choke. Once the engine has warmed up, the choke is removed and the pin replaced.

### 7.2.4 Burner System

The burners are situated in the front upper portion of the gondola. There are two burners mounted on a cross tube and inclined at 45° to the vertical. In the centre of the cross tube is a swivel block which permits the burners to be turned over so that they are pointing in the horizontal plane. This allows the burners to be tilted over for inflation, thus avoiding burn damage of the catenaries. This tilting movement is locked once the burners are in the vertical position, by inserting a pip pin through the swivel block. The burner is supported on a stainless tube which is attached to another swivel block. This second swivel block allows the burner to be rotated 180° into the gondola for more compact transportation.

The burners used are the JetStream Single burner, but with the standard liquid fire valve removed and blocked off. The main burner controls can be operated manually using the normal valve handles, or remotely by operating the hydraulic actuators. The handles for the hydraulic actuators are situated between the two flight crew seats. The hydraulic isolators must be closed before the remote burner controls are operated.

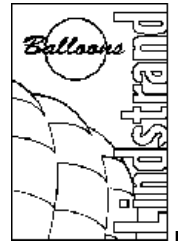

Both burners are independently supplied with propane, as shown in Figure 7.2.4. Two isolator valves are situated on the left hand side of the pilot, above head height. The propane cylinder contents are indicated on two electric gauges located between the gondola seats.

The pilot light system is based on liquid, resulting in only liquid fuel being supplied to the burners. This allows the fuel cylinders to be pressurised with Nitrogen if necessary.

The burners are both supplied with two independent forms of ignition. On each burner, the standard piezo electric igniter is fitted and additionally an electric igniter is fitted to the burner which may be operated from the sitting position.

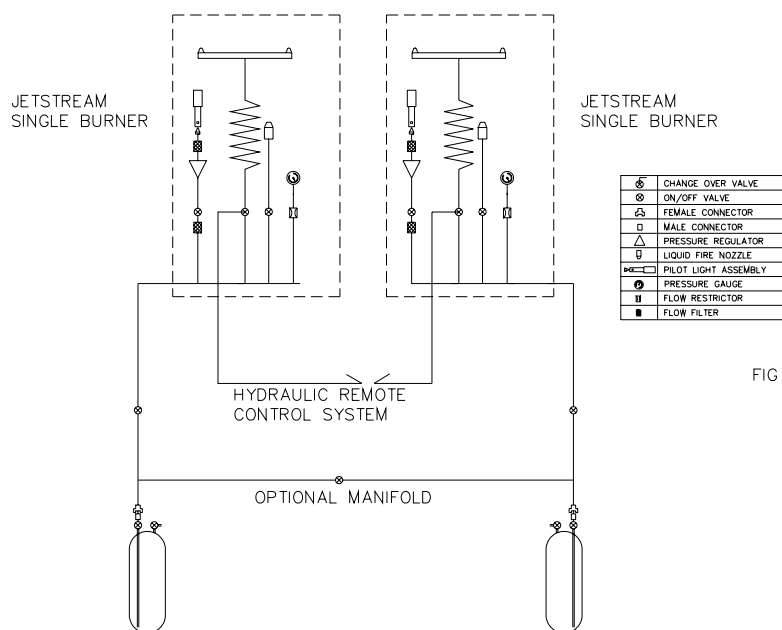

FIG 7.2.4 PROPANE SYSTEM SCHEMATIC.



### 7.2.5 Propane Cylinders

Any of the cylinders identified in Section 6.4 may be used in any combination with the gondola, provided that the liquid take-off connectors are compatible. The cylinders are secured behind the seats using three cylinder straps.

### 7.2.6 Petrol System

The fuel tank is equipped with a standard venting filler cap. The tank is made from clear plastic and has graduations on the front face showing the remaining contents. In addition, the petrol level can be easily observed by either gondola occupant at any time. The fuel system is shown on Figure 7.2.6. There are two pumps on the Rotax fuel system, one working off crank case pressure variation and one electric pump. These two pumps work in parallel to ensure sufficient fuel is supplied to the engine at any time, even if one pump fails. There are also two in-line plastic mesh filters of 0.15 mm mesh size provided in both fuel feeds to the Rotax carburetors. A shut-off valve is provided between the fuel tank and the two pumps.

The Honda fuel system is comprised of a pump located below the fuel tank which supplies fuel to a pressure regulator before passing to the Honda carburettor. A shut-off valve is also provided for on the Honda fuel system between the fuel tank and pump.

Note that all shut-off valves in the gondola are orientated such that when the handle is across the fuel line, the valve is SHUT. When the handle is in line with the fuel line, the valve is OPEN.

### 7.2.7 Instrumentation

The gondola is supplied with the following instrumentation:

- a) Flytec 3040, which provides:
  - Variometer
  - Altimeter
  - QNH setting
  - Ambient temperature
  - Envelope temperature
  - Stop watch and time
- b) Flydat engine readout, which provides:
  - Engine hours
  - Speed
  - Cylinder head temperature
  - Exhaust gas temperature
  - Coolant temperature
- c) Envelope pressure gauge
- d) Voltmeter
- e) 720 channel VHF transceiver with integral intercom (optional)
- f) Transponder with Mode C capability (optional)

The wiring diagrams are shown in Figure 7.2.7a and 7.2.7b.

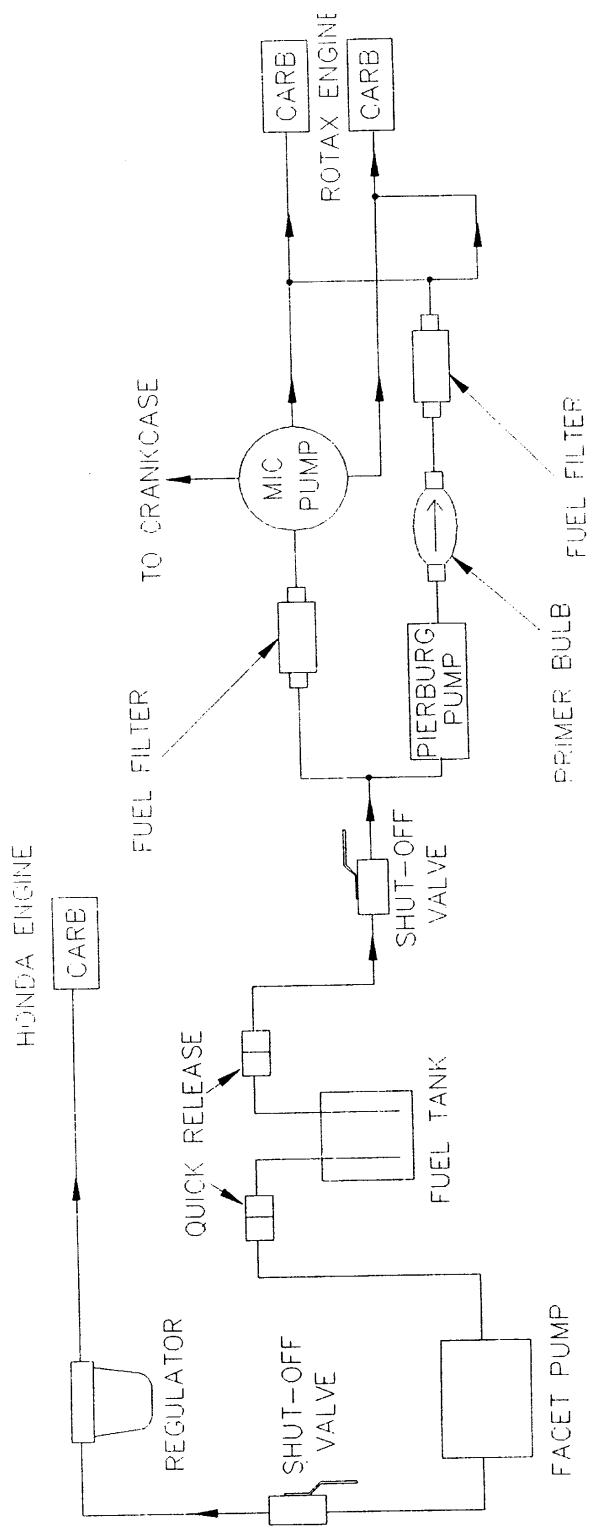

FIG 7.2.6 FUEL SYSTEM SCHEMATIC.

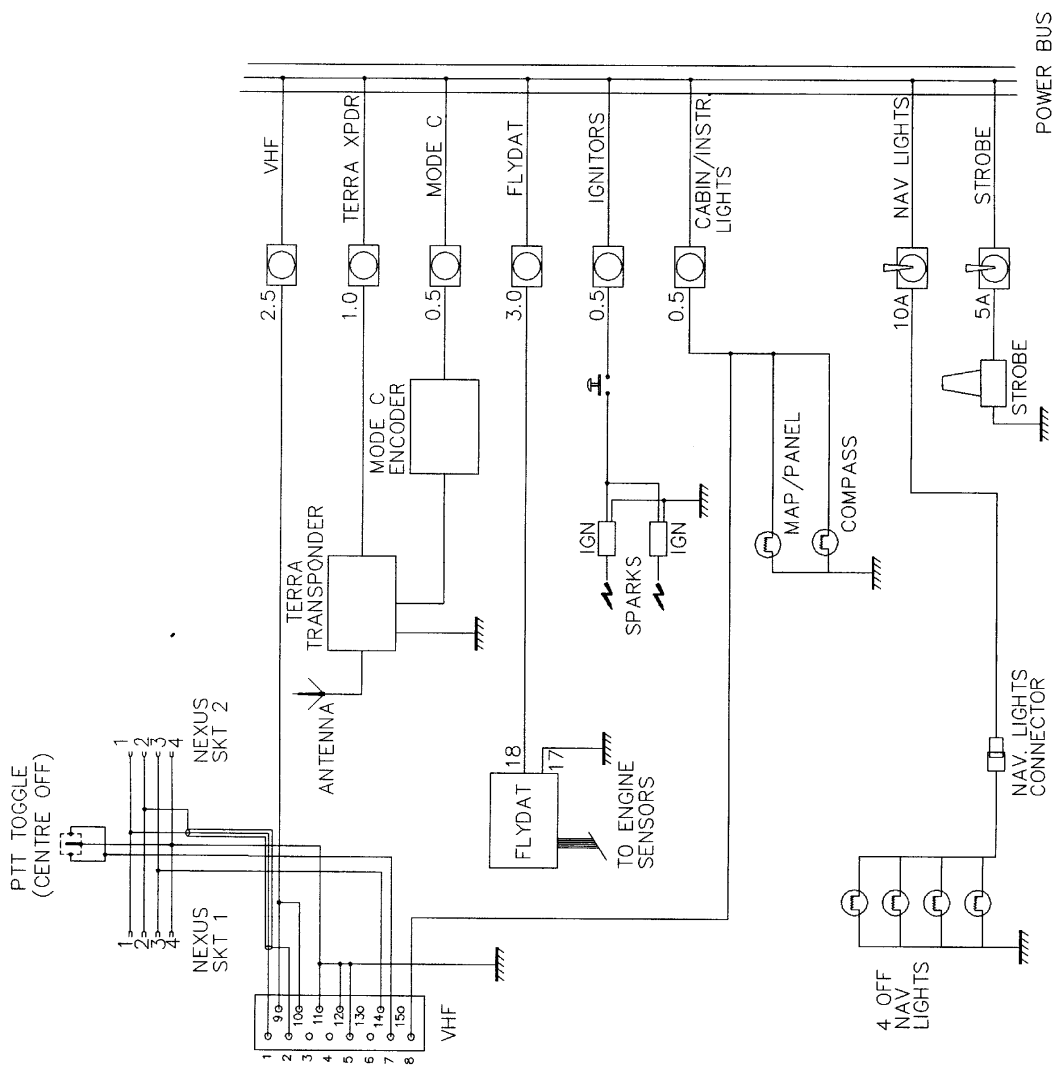

FIG. 7.2.7a WIRING DIAGRAM FOR AVIONICS & LIGHTS.

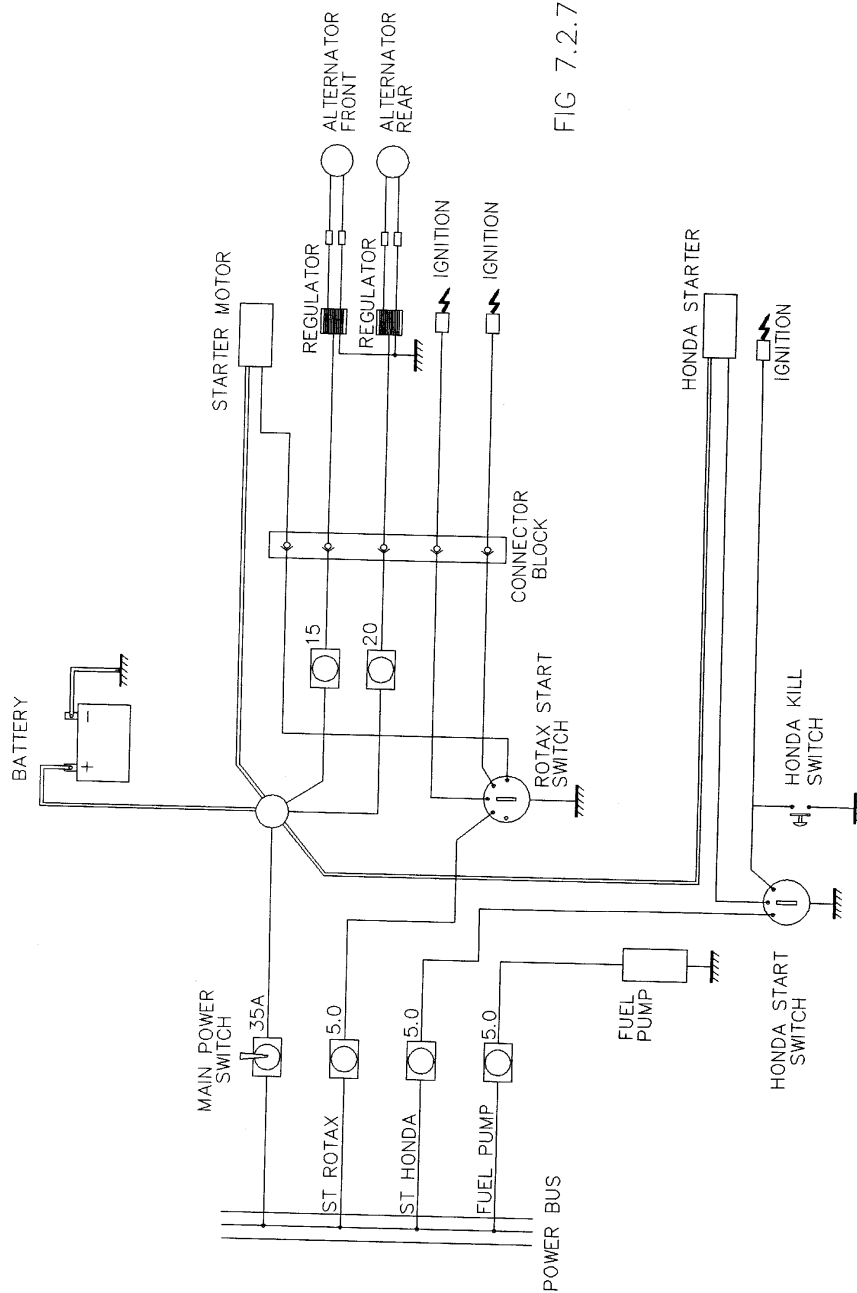

FIG 7.2.7b WIRING DIAGRAM FOR ENGINES.



## SECTION 8 HANDLING CARE AND MAINTENANCE

### 8.1 Envelope

#### 8.1.1 Envelope Handling

When handling the airship envelope, always use the seams and load tapes to hold. Do not pick up the fabric in mid-panel.

Wherever possible, choose the inflation site with the airship envelope in mind. Avoid ground which is comprised of any sharp objects which may damage the envelope. Ideally, the inflation site should be short cut grass. If other types of ground are to be used, then a ground sheet should be spread to protect the envelope.

#### 8.1.2 Envelope Maintenance

Repairs to the envelope must be performed in accordance with the instructions for repair and maintenance, contained within the Hot Air Balloon Maintenance Manual, Ref: LBL HABMM. The resulting repairs must be inspected in accordance with the instructions contained with the Maintenance Schedule for Hot Air Airships, Ref: LBL HAAMS.

### 8.2 Gondola

#### 8.2.1 Gondola Handling

The gondola is generally robust and will withstand the shocks incurred during ground handling.

Care should be employed when lifting the gondola, due to its' high weight. Any part of the metal structure may be used to manually lift the gondola. Mechanical lifting of the gondola should only be undertaken from the four main envelope attachments at the top of the framework.

When loading the gondola onto or off of a trailer, take care not to damage the aerals and anti-collision strobe light, which are all mounted underneath the gondola floor.

#### 8.2.2 Gondola Maintenance

Gondola maintenance is described within the Maintenance Schedule for Hot Air Airships, Ref: LBL HAAMS.



SECTION 9  
SUPPLEMENTS

SUPPLEMENT 1  
ENGINE INFORMATION

This section is the ROTAX Operators Manual.

Note:

- a) The "break-in procedure" detailed in this manual is carried out by Lindstrand Balloons Ltd, prior to the airship leaving the factory.
- b) With the exception of the 10 hour, 25 hour and 50 hour services detailed in Section 5, work should be carried out by workshop/person approved by the manufacturer or airworthiness authority.



## SECTION 10 NIGHT LIGHTING KIT

### 10.1 System Description

The night lighting kit is comprised of two festoons of lights for internal envelope illumination and two gondola mounted landing lights, all of which are powered by a generator which is located in place of the starboard gondola seat.

### 10.2 Installation

#### 10.2.1 Internal Envelope Lights

The internal envelope lights are best installed during cold inflation of the envelope. The two festoons of lights are identical; one is attached to the port side envelope catenaries and the other to the starboard side. The plug for the two sets of lights is located behind the starboard seat position.

#### 10.2.2 Generator

In order to install the generator, the starboard gondola seat must first be removed by undoing the two bolts which secure the base of the seat, the two nuts securing the rear of the seat frame and the bolt which anchors the top of the seat frame and the inboard shoulder strap.

Once the seat has been removed, the generator can be installed, as shown in Figure 10.2.2 and secured using the two M10 nuts used on the rear seat frame & the two 3/8" Quick Release Ball Pins from the underside. Electrical connections can then be made, as shown in Figure 10.2.2. The generator has its own supply of petrol which will last approximately 120 minutes for a full tank.

#### 10.2.3 Landing Lights

The landing lights are already installed and just require connection to the generator, as shown in Figure 10.2.2.

#### 10.2.4 Blackout Cover

The blackout cover must be used to prevent glare from the internal envelope lights and burners from distracting the pilot during night flying. It is a cover which is fitted to the top of the gondola on four hooks and can slide backwards and forwards to cover the clear envelope hatch.

### 10.3 Operation

The procedure for starting the generator is as follows:

- a. Ensure the night lighting kit is correctly installed, all connections have been made as described in Section 10.2 and that the generator fuel tank is sufficiently full. Also ensure that the blackout cover is fitted as described in Section 10.2.4.
- b. Ensure the Generator Kill rocker switch is in the 'RUN' position.
- c. Ensure the Generator Engine Switch is set to the '1 ON' position.
- d. If the engine is cold, slide the choke lever into the 'ON' position.
- e. Ensure the 'Landing Lights / Envelope Lights' rocker selector switch is in the mid 'OFF' position.

- f. Pull the start cord
- g. Leave the generator running 30 seconds or so, and move the choke lever into the 'RUN' position.
- h. The internal envelope or landing lights can then be switched on using the selector switch.

The procedure for stopping the generator is as follows:

- a. Set the Landing Lights / Envelope Lights rocker selector switch to the mid (off) position.
- b. Let the generator run for a minutes under no load to cool down.
- c. Switch off the generator from either the Kill rocker switch on the Pilot's side, or via the Engine Off switch on the outboard side.
- d. Be wary of the generator exhaust – it will be very hot.

The removal of the night lighting kit is the reverse of the installation. The internal envelope lights should be removed before packing the envelope.

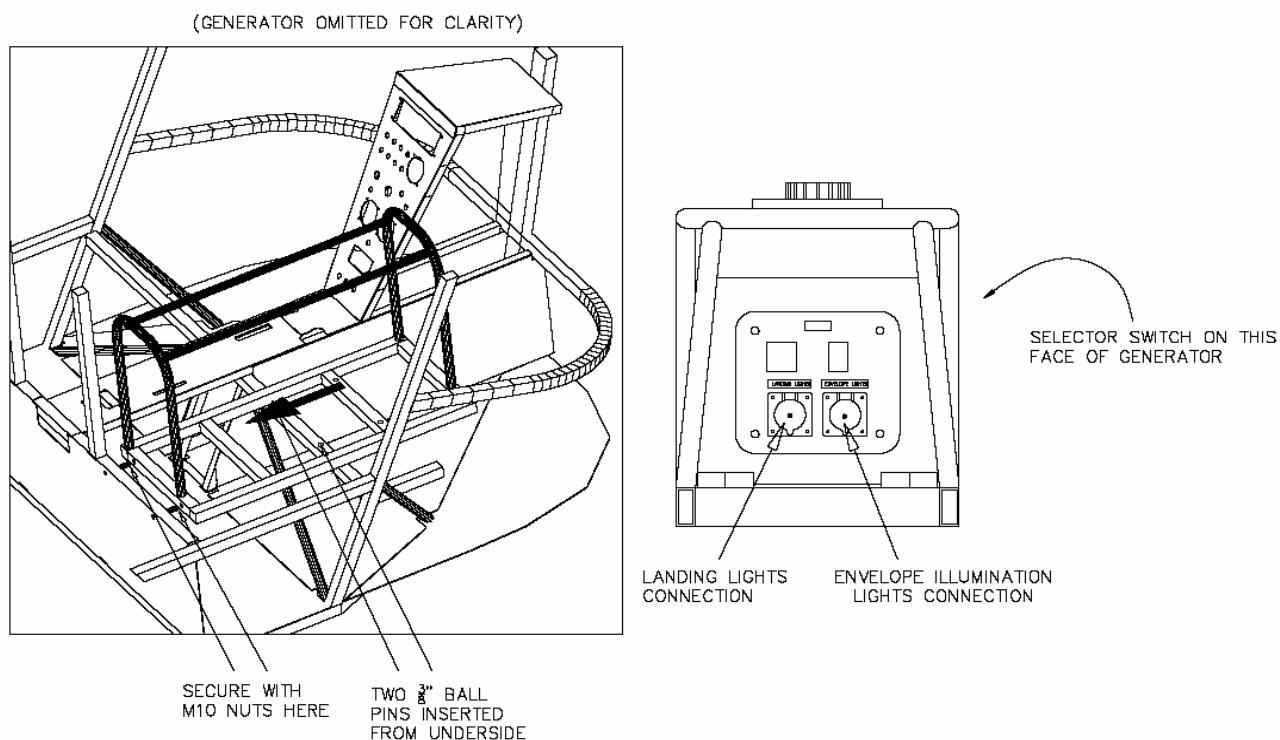

FIG. 10.2.2. INSTALLATION OF NIGHT LIGHTING GENERATOR